

# Operating Instructions Commercial Dishwasher PG 8061



To prevent accidents and machine damage, you **must** read these instructions before installation or use.

en - US, CA

# Contents

---

<b>Guide to the manual</b> .....	5
<b>Proper use</b> .....	6
<b>IMPORTANT SAFETY INSTRUCTIONS</b> .....	7
Proper installation .....	7
Technical safety .....	7
Proper use .....	9
Children in the vicinity .....	10
Accessories .....	10
Symbols attached to the commercial dishwasher .....	11
Disposal of the commercial dishwasher .....	11
<b>Appliance description</b> .....	12
Appliance overview .....	12
Control panel .....	13
<b>Caring for the environment</b> .....	14
Disposal of packaging material .....	14
Disposal of your old appliance .....	14
<b>User profiles</b> .....	15
User groups .....	15
Daily operators .....	15
Experienced operators .....	15
<b>Operation tips</b> .....	16
Display functions .....	16
Menus .....	17
Symbols in the display .....	19
<b>Commissioning</b> .....	20
<b>Opening and closing the door</b> .....	24
Convenient door lock .....	24
Opening the door  .....	24
Closing the door .....	24
Opening the door using the emergency release.....	25
<b>Filling the salt container</b> .....	26
Reactivation .....	26
Salt refill reminder.....	26
Appliance lock-out due to lack of salt.....	26
Filling the salt container .....	27
<b>Adding rinse aid</b> .....	29
Rinse aid .....	29
Rinse aid reminder .....	29
Adding rinse aid .....	30
<b>Application technology</b> .....	31
Preparing the load .....	31
Upper basket .....	33
Adjusting the upper basket .....	34
Lower basket .....	36

Use of plastic trays .....	38
<b>Operation</b> .....	40
Adding detergent .....	40
DOS module .....	42
Activation.....	45
Selecting a program .....	45
Starting a program.....	46
Program end .....	47
Deactivation.....	47
Unloading the dishwasher .....	47
Interrupting a program.....	48
Cancelling a program .....	49
<b>Program chart</b> .....	50
<b>Additional functions</b> .....	52
Delay start.....	52
Drying assistance .....	53
<b>Settings</b> ▾ .....	54
Menu structure .....	55
Delay start.....	56
Drying .....	57
Setting the language ▾ .....	58
Venting DOS modules .....	59
Setting the date .....	60
Date format.....	60
Set .....	60
Setting the clock.....	61
Set .....	61
Display.....	62
Clock format.....	62
Regulating the volume.....	63
Keypad tone .....	63
Buzzer tones.....	63
Setting the volume .....	64
<b>Additional settings</b> .....	65
Opening the "Additional settings" menu .....	65
Menu structure .....	67
CODE.....	69
Release.....	69
Changing the PIN code .....	69
Log book.....	71
Temperature unit.....	72
Move program .....	73
Additional functions.....	74
Reset .....	74
Increased water level.....	75
Interim rinse.....	75
DOS dispensing systems .....	76
Temperature / time .....	79

# Contents

---

Main wash / Final rinse.....	80
Final rinse temperature.....	80
Holding time.....	81
Program release.....	82
Water hardness.....	83
Settings table.....	84
Display view.....	85
Display.....	86
Contrast.....	86
Brightness.....	87
Switch off after.....	88
Factory default setting.....	89
Software version.....	90
<b>Cleaning and care.....</b>	<b>91</b>
Cleaning the control panel.....	91
Cleaning the appliance front.....	91
Cleaning the wash cabinet.....	91
Cleaning the door and the door seal.....	92
Cleaning the filters in the wash cabinet.....	92
Cleaning the spray arms.....	94
<b>Frequently asked questions.....</b>	<b>96</b>
Technical problems.....	96
Unusual behavior of the dishwasher.....	98
Noises.....	99
Poor cleaning results.....	100
<b>Frequently asked questions.....</b>	<b>102</b>
Cleaning the filters in the water inlet.....	102
Cleaning the drain pump and non-return valve.....	103
<b>After sales service.....</b>	<b>105</b>
<b>Installation.....</b>	<b>106</b>
Installation.....	106
Floor anchors for free-standing units.....	108
Moving the dishwasher.....	108
<b>Electrical connection.....</b>	<b>109</b>
<b>Plumbing.....</b>	<b>110</b>
Connecting the water supply.....	110
Connecting the water drain.....	112
<b>Technical details.....</b>	<b>113</b>

### Warnings

 Information which is important for safety is highlighted in a thick framed box with a warning symbol. This alerts you to the potential danger of injury to people or property. Read these warning notes carefully and observe the procedural instructions and codes of practice they describe.

### Notes

Notes contain information that is particularly important to follow. They are highlighted by a thick frame.

### Additional information and comments

Additional information and comments are highlighted by a thin frame. They are not imperative for the operation of the commercial dishwasher.

### Operating steps

Additional instructions on how to operate the dishwasher are described step by step in a logical sequence. Each step is introduced using a black square bullet point.

Example:

- Open the dishwasher door.

### Display

Information given via the display of the dishwasher appears in a special display font.

**Example:**

Select Delay start and confirm the entry with the *OK* button.

## Proper use

---

### Proper use

This commercial dishwasher complies with current safety requirements. Inappropriate use can, however, lead to personal injury and damage to property.

To avoid the risk of accidents and damage to the dishwasher, please read these instructions carefully before using it for the first time. They contain important information on its safety, installation, use and maintenance. Keep these instructions in a safe place and pass them on to any future owner.

▶ With its short program running times and powerful cleaning performance, this Miele commercial dishwasher is intended for commercial use in the following:

- Guest houses
- School and day care centers, Restaurants and catering
- Nursing homes
- Other, similar commercial environments

▶ This appliance is designed exclusively for use as a "dishwasher" for cleaning cookware, glassware and cutlery only, as described in these instructions. Alterations or conversions to the dishwasher, or using it for purposes other than those for which it is designed, are not permitted and could be dangerous.

Miele cannot be held liable for damage caused by improper or incorrect use or operation.

▶ This commercial dishwasher is intended only for stationary indoor use.

▶ The special inserts are to be used for their specific purpose only.

▶ This commercial dishwasher is not suitable for the cleaning of medical products or devices.

▶ Persons who lack physical, sensory or mental abilities, or experience with the appliance should not use it without supervision or instruction by a responsible person.

# IMPORTANT SAFETY INSTRUCTIONS

---

## Proper installation

- ▶ Do not install the commercial dishwasher in areas at risk of explosion or freezing.
- ▶ To ensure the stability of undercounter commercial dishwashers, they must only be installed beneath a continuous countertop that is bolted to the adjacent cabinetry.
- ▶ In order to reduce the risk of damage from condensation, the furniture in the area around the commercial dishwasher should be designed for commercial use.

## Technical safety

- ▶ The commercial dishwasher must only be installed, commissioned, repaired and then maintained by the Miele Service Department or an authorized Miele Service dealer. Installation, repair and other work by unqualified persons could be dangerous and Miele will not be held liable.
- ▶ This commercial dishwasher must only be operated by appropriately trained personnel. They must be instructed and trained regularly.
- ▶ Before using the commercial dishwasher, check it for any externally visible damage. Under no circumstances should you use it if it has been damaged. It could be dangerous.
- ▶ In the event of a damaged or leaking commercial dishwasher, turn it off immediately and contact Miele or an authorized Miele Service dealer.
- ▶ Faulty components may only be replaced by genuine Miele original parts. Only when these parts are fitted can Miele guarantee the safety standards of the appliance.
- ▶ The electrical safety of this commercial dishwasher can only be guaranteed when it is connected to a correctly installed grounding conductor system. If in any doubt, please have the electrical installation tested by a qualified electrician. Miele cannot be held liable for the consequences for the lack or interruption of a grounding conductor (e.g. electric shock).
- ▶ Be sure to follow the installation instructions in this manual and in the installation diagram.
- ▶ Ensure that the connection data on the data plate (voltage, frequency, and fuse rating) match those of your electrical supply.
- ▶ There must be no electrical sockets behind the commercial dishwasher since the depth of the installation niche may be too small and there is a danger of overheating if the dishwasher is pushed up against a plug (see the "Electrical connection" chapter for more information).

## IMPORTANT SAFETY INSTRUCTIONS

---

- ▶ Do not connect the dishwasher to the electrical supply by a multiple outlet box or an extension cable since they do not guarantee the required safety of the appliance (e.g. danger of overheating).
- ▶ Do not open the commercial dishwasher casing under any circumstances. Tampering with electrical connections or components and mechanical parts is highly dangerous to the user and can cause operational faults.
- ▶ The commercial dishwasher must not be used if the connecting cable is damaged. If the cable is damaged, it must be replaced with a special connecting cable available from Miele. For safety reasons, this may only be performed by the Miele Service Department or an authorized Miele Service dealer.
- ▶ Before maintenance, disconnect the commercial dishwasher from the electrical supply.
- ▶ The plastic housing of the water connection contains electrical components. It must not be dipped in water.
- ▶ There are live wires in the water inlet hose. Do not shorten the water inlet hose, even if it is too long.
- ▶ The built-in waterproof system offers reliable protection against water damage if the following conditions are met:
  - proper installation
  - proper maintenance of the dishwasher or exchange of parts in case of visible damage
  - closing of the water valve during longer absences (for example vacation)

The waterproof system will work even if the dishwasher is turned off. However, the commercial dishwasher must remain connected to the electrical supply.



# IMPORTANT SAFETY INSTRUCTIONS

---

## Proper use

- ▶ This commercial dishwasher is designed for operation with water and detergents suitable for use in commercial dishwashers only. Organic solvents and flammable liquid agents must not be used. This could cause an explosion, property damage due to the destruction of rubber or plastic, and the resulting leakage of liquids.
- ▶ Use detergents formulated for use in commercial dishwashers. Using unsuitable detergents could damage the dishes and the commercial dishwasher itself.
- ▶ Do not sit or lean on the opened door. This could cause the commercial dishwasher to tip or become damaged.
- ▶ After any plumbing work on the water supply, to the dishwasher will need to be vented. If this is not done, components can be damaged.
- ▶ Please be aware that the dishwasher may be operating at high temperatures. If the door is opened, there is a danger of burning or scalding. Dishes, cutlery, baskets, and inserts must be allowed to cool down before they are unloaded. Any water remaining in containers could still be very hot. Empty them into the wash cabinet before taking them out.
- ▶ The water in the wash cabinet is NOT safe to drink!
- ▶ The pretreatment of items (for example with dishwashing liquid and other detergents), but also some types of soiling and some detergents, can cause a build-up of foam in the wash cabinet. Foam can have an adverse effect on the cleaning result.
- ▶ Foam escaping from the wash cabinet can cause damage to the dishwasher. If foam escapes, the program must be cancelled immediately.
- ▶ When using detergents and specialized products, it is essential that the manufacturer's instructions are followed. Detergents must only be used for the purpose they are designed for and in the situation specified, to avoid material damage and serious chemical reactions (e.g. oxyhydrogen explosion).
- ▶ Do not inhale or ingest powder detergent. Dishwasher detergents contain irritant or corrosive ingredients which can cause burning in the nose, mouth and throat if swallowed, or inhibit breathing. Seek medical attention immediately if detergent has been swallowed or inhaled.
- ▶ Miele cannot be held liable for any effect chemical detergents may have on the material of the items being cleaned. Observe the detergent manufacturer's instructions with regard to storage conditions, use, and dosage.

## IMPORTANT SAFETY INSTRUCTIONS

---

- ▶ To avoid material damage and corrosion, do not allow any acids or solutions containing chloride to get into the wash cabinet. Similarly avoid any materials with a corrosive effect.
- ▶ Do not wash items soiled with ash, sand, wax, lubricants, or paint in the dishwasher. These substances could damage the dishwasher.
- ▶ Do not hose down the dishwasher or its direct vicinity to clean it, e.g. with a water hose or high-pressure cleaner.
- ▶ Ensure that the stainless steel outer casing of the appliance does not come into contact with solutions or steam containing acid to avoid any corrosion damage.
- ▶ Be careful when sorting items with sharp pointed ends and positioning them in the dishwasher so that you do not hurt yourself or create a danger for others. Cutlery should be placed in baskets in such a way that no injuries can occur.
- ▶ Remove any coarse food deposits from the items being cleaned before loading them in the dishwasher.

### **Children in the vicinity**

- ▶ Supervise children when they are anywhere near this dishwasher. Do not let them play with it. There is a danger that children may lock themselves in the dishwasher.
- ▶ Children must not be allowed to operate this dishwasher.
- ▶ Keep children away from chemical agents. These contain irritant and corrosive ingredients which can cause burning in the mouth, nose and throat if swallowed, or inhibit breathing. Keep children away from the dishwasher when the door is open. There could still be residual chemical agent in the cabinet. Seek medical advice immediately if a child has swallowed or inhaled chemical agent.

### **Accessories**

- ▶ Only use genuine Miele original spare parts and accessories with this dishwasher. Miele will provide you with the article designations of the accessories.
- ▶ Only use Miele baskets and inserts with this dishwasher. Using baskets and inserts made by other manufacturers, or making modifications to Miele accessories can cause unsatisfactory cleaning results, for which Miele cannot be held liable. Any resultant damage would not be covered by the guarantee.

# IMPORTANT SAFETY INSTRUCTIONS

## Symbols attached to the commercial dishwasher

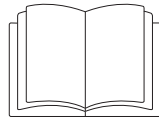

Attention:  
Observe the operating instructions



Attention:  
Danger of electric shock!

## Disposal of the commercial dishwasher

- ▶ For safety and environmental reasons, dispose of all process chemicals according to the manufacturer's instructions and to safety regulations. Safety goggles and protective gloves should be worn.
- ▶ Remove or disable the door lock prior to disposal of the dishwasher, so that children cannot become trapped inside (see "Caring for the environment").

Miele cannot be held liable for damage caused by failure to comply with these safety instructions and warnings.

# Appliance description



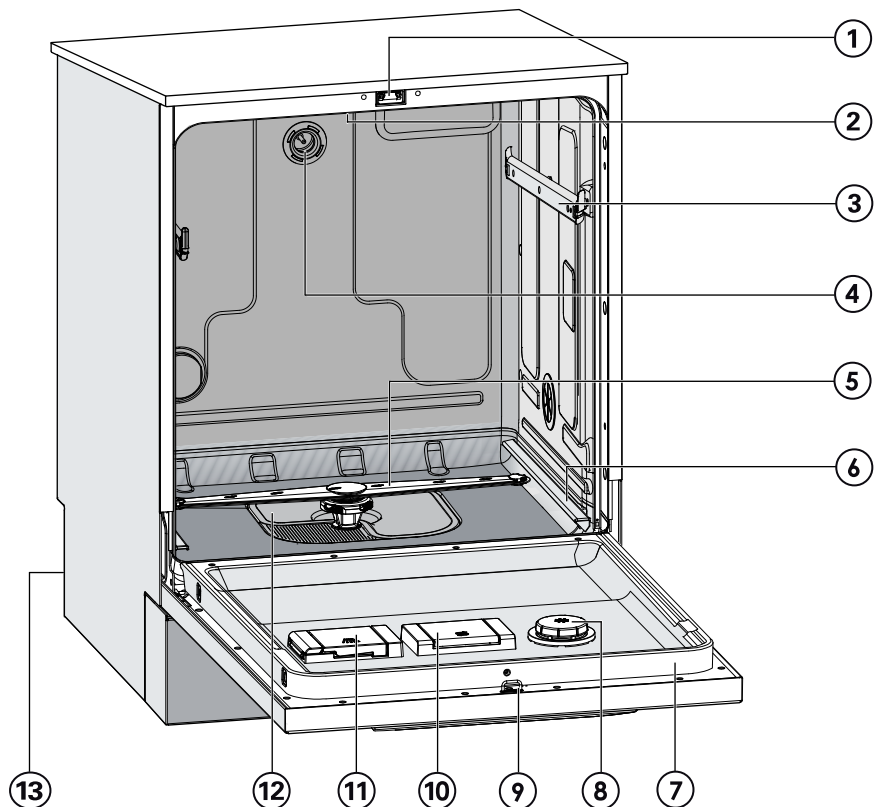



## Appliance overview

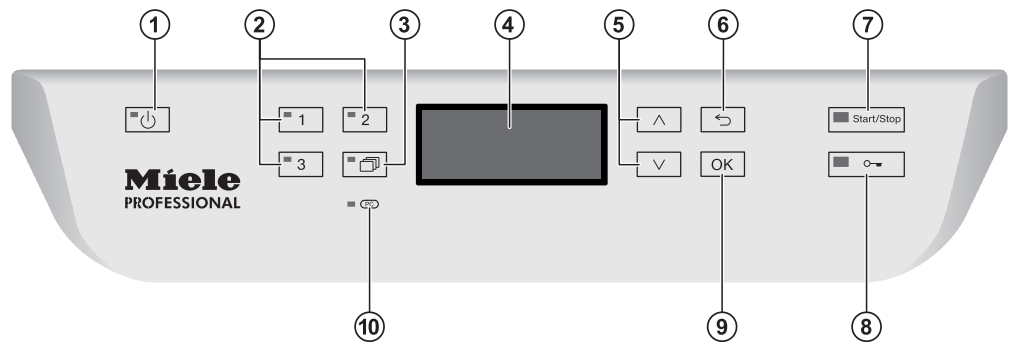

- ① Door lock
- ② Upper spray arm (not visible)
- ③ Runner for upper basket
- ④ Connection for upper basket spray arm
- ⑤ Lower spray arm
- ⑥ Runner for lower basket
- ⑦ Data plate
- ⑧ Rinse aid reservoir
- ⑨ Door lock barrel
- ⑩ Reservoir for reactivation salt
- ⑪ Dispenser for powder detergent
- ⑫ Filter combination
- ⑬ Back:
  - Connection for DOS modules
  - External dispensing pump for liquid detergent (DOS1)
  - External dispensing pump for rinse aid (DOS4)

## Control panel



- ①  button (On/Off)  
For turning the dishwasher on and off
- ② Buttons 1 - 3 (program selection buttons)  
Shortcut buttons for storing favorite programs
- ③  button (additional programs)  
For selecting additional programs
- ④ Display  
User interface output
- ⑤  and  button (arrow buttons)  
Navigation in user interface
- ⑥  button (cancel or back)  
For canceling a process in the user interface  
(not for canceling programs)
- ⑦ *Start/Stop* button  
For starting or cancelling a program
- ⑧  button (door release)  
For opening the door or interrupting a program
- ⑨ *OK* button (confirmation)  
For selecting or confirming entries in the user interface
- ⑩ Optical interface   
Testing and transmission point for Miele customer service technicians.

## Caring for the environment

---

### **Disposal of packaging material**

The packaging is designed to protect the dishwasher from damage during transportation. The packaging materials used are selected from materials which are environmentally friendly for disposal and should be recycled.

Ensure that any plastic wrappings, bags, etc. are disposed of safely and kept out of the reach of children. Danger of suffocation!

### **Disposal of your old appliance**

Old electrical and electronic appliances often still contain valuable materials. However, they also contain harmful substances that were essential for the proper functioning and safe use of the equipment. Handling these materials improperly or disposing of them in your household waste can be harmful to your health and the environment. Therefore, please do not dispose of your old appliance with regular household waste.

Instead, use your local community waste collection and recycling center to dispose of your old electric and electronic appliances. If necessary, ask your dealer for more information.

Ensure the appliance presents no danger to children while being stored for disposal.

### User groups

Users can be divided into two groups:

- Daily operators
- Experienced operators

Access to "Additional settings" can be blocked to general, daily operators by using a code (see "Additional settings, Code").

### Daily operators

Daily operators must be instructed in operating and loading the dishwasher and trained regularly to guarantee safe daily use.

### Experienced operators

Experienced operators can additionally block access to programs, modify temperature and holding times within program cycles, and alter water levels.

### Display functions

The display is not a touch screen.

The following functions can be selected or set with the display:

- The program
- The delay start time
- The settings

The following appears in the display while a program is running:

- The program name
- The program stage / target temperature / actual temperature
- The estimated time left for the program to run
- Any relevant fault messages and information

### Menu operation

This dishwasher is operated exclusively via buttons on the control panel. Arranged to the side of the display, the buttons (button fields) are printed on the stainless steel control panel. They are operated by pressing gently.



Menu operation is via the keypad to the right of the display.

- ^ button  
For navigating upwards by row within a menu, or increasing the value highlighted.
- ↶ button (Cancel or back)  
For ending a menu early. Any changes to settings are not saved and the display reverts to the previous menu.
- v button  
For navigating downwards by row within a menu, or decreasing the value highlighted.
- OK button  
For confirming a selection or for saving input. The display moves to the next menu or, when entering values, to the next input position. The procedure for entering the values is described in the respective chapter.



### Menus

The user interface of the commercial dishwasher is divided into menus. The menus are displayed in a 3-line display on the control panel.

Example:



The name of the menu and a maximum of two options are shown. The currently selected option is highlighted.

### Simple selection



The arrow buttons  $\wedge$  and  $\vee$  are used for navigating within the menu. The highlighted option is selected by pressing the *OK* button. Once selected, the option will have a tick  $\checkmark$  beside it. Other options are automatically deselected.

Press the *OK* button to progress to the next menu, or to the next input position when confirming values. The procedure for entering the values is described in the respective chapter. Press the  $\leftarrow$  button to revert to the previous menu without saving the entry.

### Multiple selection

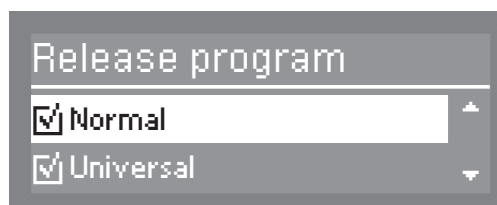

The  $\wedge$  and  $\vee$  arrow buttons are used for navigating within the menu. Several options can be selected in succession within the menu using the *OK* button. Once selected, an option will have a tick  $\checkmark$  beside it. To save your chosen options, select *Accept* and confirm with the *OK* button.

## Operation tips

---

**System messages** The **i** symbol denotes system messages. These give information about current processes and the status of the dishwasher. System messages are displayed individually at the end of the program. If there are a number of system messages, subsequent messages can be displayed by pressing *OK*. A system message can be recalled by pressing *OK* during a program cycle.

Example:

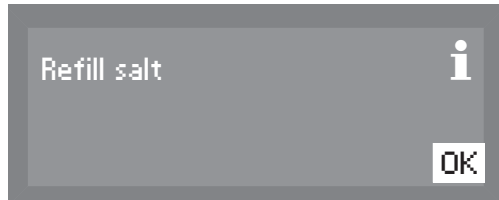

### Automatic switch-off

The dishwasher has an automatic switch-off function. The dishwasher switches itself off automatically after the time set. The display and all other LEDs are switched off. To switch the dishwasher on press the On/Off  button.

Automatic switch-off can be deactivated (see "Additional settings, Switch off after"). The display will then remain switched on in standby mode.

## Symbols in the display

**Navigation arrows**  If a menu contains more than two options, two navigation arrows are shown beside the options. The arrow buttons  $\wedge$  and  $\vee$  can be used to scroll through the options.

**Dotted line** ----- If a menu contains more than two options, the end of the option list is marked by a dotted line. The last entry appears above the line, the first entry below it.

**Tick**  $\checkmark$  If there are several options available, the current setting is marked with a tick  $\checkmark$ .

Example:



**Drying**  $\underline{\underline{\underline{\hspace{0.5em}}}}$  If drying assistance has been activated, the drying symbol will be displayed to the right of the program name.

Example:

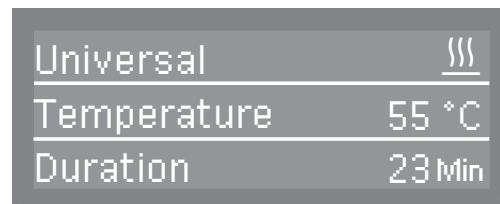

**System messages** **i** The **i** symbol denotes system messages and is displayed alternately with the  $\underline{\underline{\underline{\hspace{0.5em}}}}$  symbol. If OK appears in the bottom right of the display, the system message must be confirmed using the OK button. If OK does not appear in the display, after a few seconds the display skips to the next level up.

**Fault messages**  In the event of a fault, a warning triangle is shown in place of the **i** symbol. See "Frequently asked questions" for more information.

# Commissioning

---

## Commissioning

During commissioning, the following settings must be carried out. You will be asked to program settings one after the other automatically, and currently selected values have a tick ✓ beside them. The commissioning process requires a set period of time which cannot be interrupted.

The dishwasher will guide you automatically through the steps required.

Reactivation is carried out during the first program following commissioning.

If the first program after commissioning is not completed and the dishwasher is then turned off, the commissioning process must be carried out again.

The following options (with the exception of "Plumbing connections") can be altered retrospectively via the "Settings" menu and "Additional Settings."

## Activation

The dishwasher must be connected to the electrical supply.

- Press the  button until the LED on the keypad lights up.

## Setting the language

The commissioning process starts automatically with setting the language. You are prompted to set the display language.

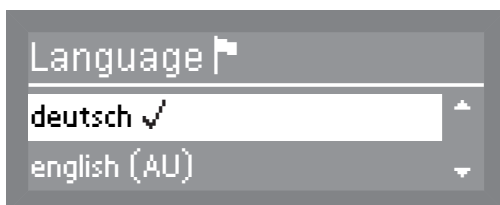

- Use the  $\wedge$  and  $\vee$  arrow buttons to select the language you want and confirm your choice using the *OK* button.

## Setting the temperature unit

The display will change to the screen for setting the temperature unit.

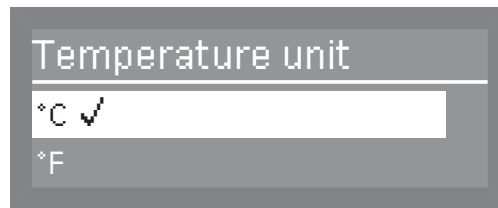

- Use the  $\wedge$  and  $\vee$  arrow buttons to select the temperature unit you want and confirm your selection using the *OK* button.

## Setting the date format

The display will change to the screen for setting the date format.

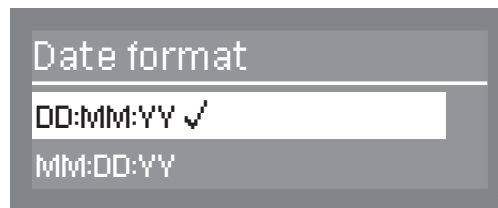

- Use the  $\wedge$  and  $\vee$  arrow buttons to select the date format you want and confirm your choice using the *OK* button.

## Setting the date

The display will change to the screen for setting the date.



- Use the arrow buttons  $\wedge$  (higher) and  $\vee$  (lower) to set the day, month and year and confirm each entry using the *OK* button.

## Setting the clock format

The display will change to the screen for setting the clock format.

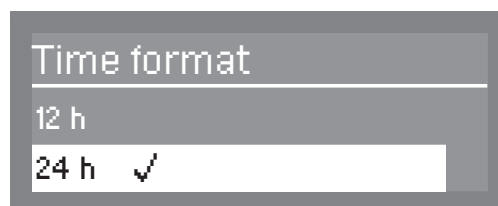

- Use the  $\wedge$  and  $\vee$  arrow buttons to select the format you want and confirm your choice using the *OK* button.

# Commissioning

**Setting the clock** The selected clock display is shown.



- Use the arrow buttons  $\wedge$  (higher) and  $\vee$  (lower) to set the hours and minutes and confirm each entry using the *OK* button.

If you have selected 12 h for the clock, "am" or "pm" will appear beside the time.

## Setting the water hardness level

The display changes to the water hardness setting.

The dishwasher must be programmed to exactly match the hardness of your water.

- Your local water supplier can tell you the water hardness level in your area.
- Where the water hardness fluctuates (e.g. 16-28 gpg / 15-27°dH), always program the dishwasher to the higher value (in this example, 28 gpg / 27°dH).

It is useful to know your water hardness so that you can provide the service technician with this information in the event of any service calls.

- Enter the water hardness below:

\_\_\_\_\_ gpg / °dH

The dishwasher is programmed at the factory for a water hardness level of 20 gpg (19°dH).

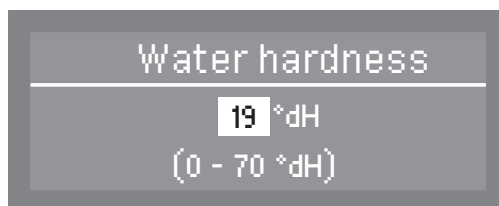

- Use the arrow buttons  $\wedge$  (higher) and  $\vee$  (lower) to set the water hardness required and confirm your entry using the *OK* button.

See "Additional settings menu, Water hardness" for more information.

## Plumbing connections

The display will then change to the screen for setting the plumbing connection.

This setting can be turned off if the dishwasher cannot be connected to all available plumbing connections.

If individual plumbing connections are turned off, they can only be reactivated by Miele Service.



- Use the  $\wedge$  and  $\vee$  arrow buttons to select the plumbing connections which are not connected and confirm your choice using the *OK* button.

The tick  $\checkmark$  will be removed from the box  and the plumbing connection is now turned off.

- Select *Accept* to save your selection and confirm using the *OK* button.

## Commissioning completed

Commissioning is successfully completed and the following message will appear in the display.

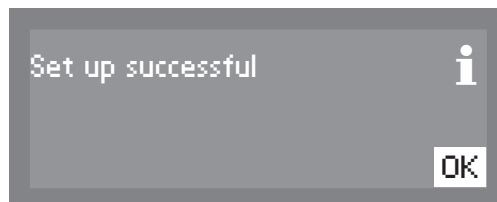

- Press the *OK* button.

The dishwasher is now ready for use.



The start screen is displayed for 3 seconds.

Then the first shortcut button program will appear in the display.

## Opening and closing the door

---

### Convenient door lock

This dishwasher is equipped with a convenient door lock.

This door locking mechanism helps drying by opening the door by a couple of centimeters at the end of the program (except *Reactivation, Cold and Drain*) This function can also be deactivated (see "Settings", *Drying*).

### Opening the door

The door can only be opened if the dishwasher is connected to the electrical supply and is turned on (the LED  is lit on the keypad).

The control panel also serves as a door handle.

- Press the  button to open the door. The LED on the keypad turns off as soon as the door is unlocked.
- Grasp the handle underneath the control panel and lower the door to open.

Pressing the  button during operation can interrupt the program (see "Operation, Interrupting a program").

A program which is already running should only be interrupted if absolutely necessary, e.g. if the wash load is moving significantly.

### Closing the door

- Insert the baskets.
- Raise the door upwards and push it gently until the latch audibly engages. The door will be drawn automatically into its final closed position by the closing mechanism.

 Do not touch the door frame.  
Risk of injury!

If the door cannot be closed properly by the mechanism because it is obstructed by cookware or similar, a three-digit error code will appear in the display (see "Frequently asked questions").

- Remove the obstruction from the vicinity of the door.

If too much force is used when closing the door, the automatic closing mechanism may not work, which may result in the door not being properly closed.

The dishwasher can only be guaranteed as waterproof if the automatic closing mechanism has drawn the door into the final closed position.



### Opening the door using the emergency release

⚠ The emergency release should only be operated when it is no longer possible to open the door in the usual way.

⚠ If the emergency release is operated during a program cycle, hot water can escape.  
Danger of scalding and burning.

The emergency release mechanism is located on the right beside the door lock between the door and the lid of the appliance (or the counter, with built-under appliances).

The emergency release is operated using the tool supplied in the accessory pack with the operating instructions.

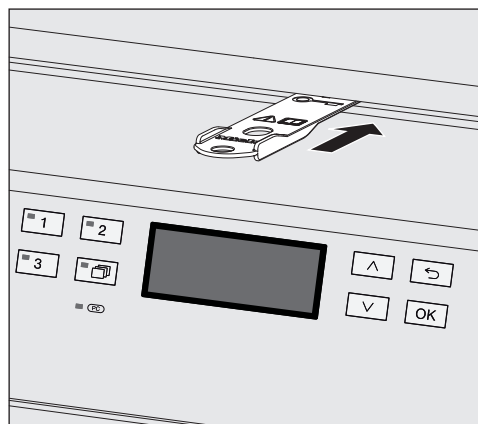

- Insert the tool for the emergency release into the gap between the lid and the door to the right of the lock. The right hand edge of the tool should ideally be aligned with the right hand edge of the display.
- Push the slider for the emergency release backwards with the tool until the door opens slightly.

If you push against the door of the dishwasher at the same time, less force will be needed to operate the emergency release.

When the door has been opened using the emergency release, the following message will appear in the display:

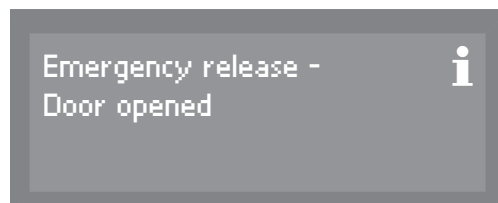

Confirm the message after the door has been released from the closing mechanism. The last program used will then appear in the display.

## Filling the salt container

### Reactivation

In order to achieve good cleaning results, the dishwasher water needs to be softened. The water is softened automatically in the water softener.

Dishwasher salt is required for reactivation and the degree of water hardness must be set on the dishwasher to ensure problem-free functioning of the water softener (see "Additional settings, Water hardness").

If the hardness of your water constantly lies under 4 gpg (4 °dH), no salt must be filled in the water softener.

⚠ Do not fill the salt container with dishwasher detergent (even liquid detergent).

Dishwasher detergent will damage the water softener.

Use only special, coarse-grained reactivation salt or other pure kitchen salt.

Other types of salt may contain insoluble components which can damage the water softener.

**Salt refill reminder** ■ At the end of a program, fill the salt reservoir with salt as soon as the message appears in the display.

■ Confirm the message with the *OK* button.

If salt is not added, the **i** symbol indicating a lack of salt will appear beside the program name on the right.

At the end of each program, the lack of salt message appears again.

Refill reminders can be displayed during the program cycle by pressing the *OK* button.

If there are no additional refill reminders, the **i** symbol in the display will go out after a few seconds after the salt has been refilled.

The salt refill reminder is deactivated if the dishwasher is set to a water hardness of 0 - 4 gpg (0 - 4 °dH).

### Appliance lock-out due to lack of salt

If the refill salt reminder is ignored for several program cycles and the salt is not refilled, the appliance will lock itself against additional use until it is refilled.

The following message will appear in the display shortly before this happens:

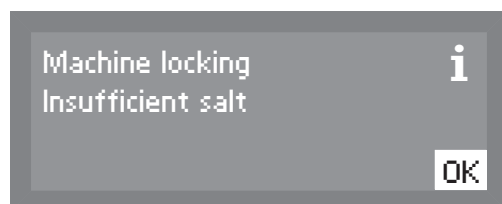

## Filling the salt container

Only a few more program cycles are possible, depending on the program selected and the water hardness set.

The dishwasher is locked against operation if additional program cycles are run without salt being refilled.

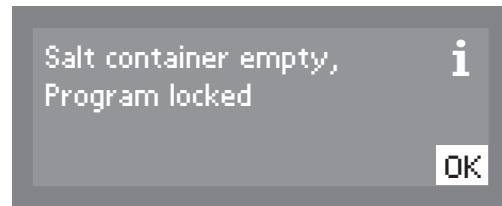

When reactivation salt is added, the appliance will unlock itself after a few seconds.

### Filling the salt container

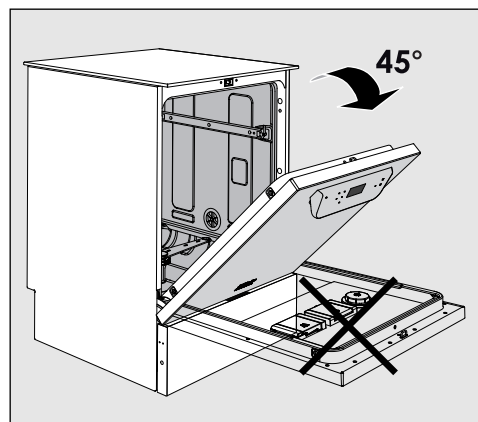

- Only open the door **half way** when adding salt to avoid spilling it.

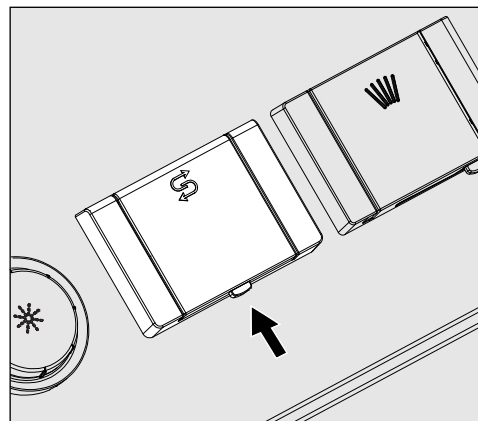

- Press the button on the lid of the salt reservoir in the direction of the arrow until the flap springs open.
- Open the funnel.

Do **not** fill water into the salt reservoir!

## Filling the salt container

---

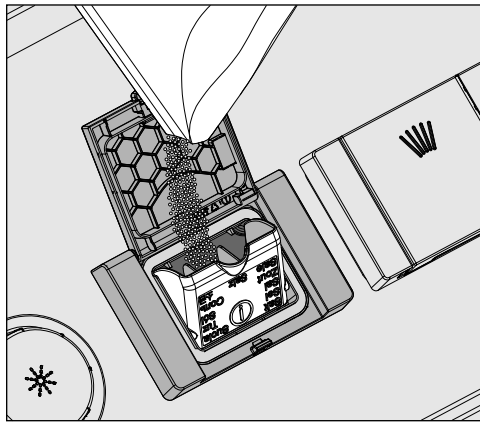

- Add salt only until the funnel of the salt reservoir is full, so that it can close properly. The salt reservoir will hold approx. 4.4 lbs (2 kg) of salt on the first fill depending on the degree of coarseness. Subsequent refills may take less salt, as there may still be salt remaining in the reservoir.

Do not add any more than 4.4 lbs (2 kg) of salt.

Displaced water may run out as the reservoir is being filled.

- Clean any excess salt from around the reservoir opening and the seal around it, and then close the flap.
- After refilling the salt reservoir, run the **Cold** program immediately (without any cookware in the dishwasher) to remove any traces of salt from the cabinet.

### Rinse aid

Rinse aid is necessary to ensure water does not cling and leave marks on cookware before the drying phase and helps cookware dry faster after it has been washed.

Rinse aid can be poured into the reservoir in the door or can be dispensed via an external dispensing DOS module (Optional accessory - see "DOS module").

 Only fill the rinse aid reservoir with rinse aid. Do not fill it with detergent (including liquid detergent). This will seriously damage the reservoir.

Conversion to the external DOS module must be carried out only by Miele Service or by an authorized dealer.

### Rinse aid reminder

- Refill rinse aid at the end of a program as soon as the message appears in the display.

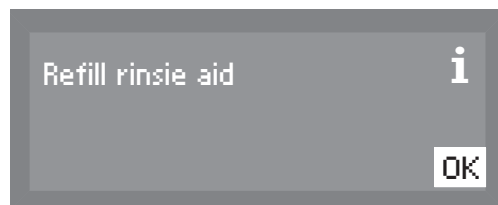

- Confirm the message with the *OK* button.



If rinse aid is not added, the **i** symbol indicating a lack of rinse aid will appear beside the program name on the right.

The refill reminder will be displayed again at the end of every subsequent program.

Refill reminders can be displayed during the program cycle by pressing the *OK* button.

If there are no additional refill reminders, the **i** symbol in the display will go out a few seconds after the rinse aid has been refilled.

## Adding rinse aid

---

- Adding rinse aid** ■ Open the door **all the way**.

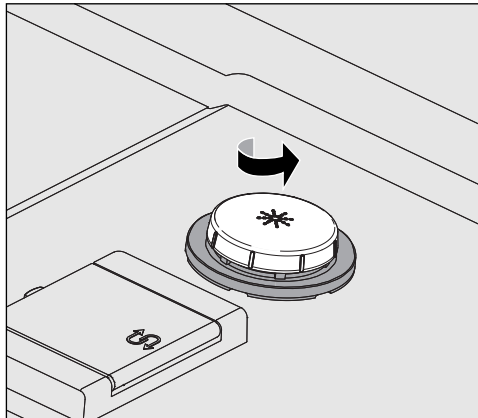

- Unscrew the lid of the rinse aid reservoir.

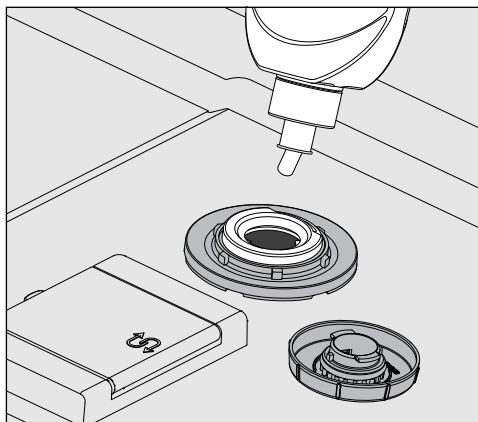

- Add rinse aid only until it is up to the maximum mark on the edge of the reservoir.

The rinse aid reservoir holds approx. 10 oz (300 ml).

- Screw the lid of the rinse aid reservoir back on tightly so that water cannot get into the reservoir during the wash cycle.
- Clean up any spilled rinse aid. This prevents over-foaming from occurring during the next program.

You can adjust the dosage of the rinse aid for best results (see "Additional settings, Additional functions").

### Preparing the load

Remove coarse food residues from the dishware.

There is no need to rinse items under running water!

Tips:

⚠ Ensure that no acid or solvent residues, especially hydrochloric acid or chlorides, get inside the machine.

⚠ Do not wash items soiled with ash, sand, wax, grease or paint in the dishwasher.

These substances will damage the dishwasher.

- Load the respective cookware and utensil into the appropriate places in the baskets, but observe the following instructions:
- Load the cookware so that water can access all surfaces. This ensures that they get properly cleaned.
- Load plates symmetrically in the upper and lower baskets with the concave surface towards the center of the basket (as shown on the following pages).
- Do not place dishes or cutlery inside other pieces. They will cover each other.
- Make sure that all items are securely positioned.
- Hollow items such as cups, glasses, pans, etc. must be inverted in the basket.
- Tall, narrow, hollow items should be placed in the center of the basket if possible to ensure better water coverage.
- Concave items such as mugs or bowls should be placed at an angle so that the water can run off.
- The spray arms must not be blocked by items which are too tall or hang through the baskets. If in doubt, test for free movement by manually rotating the spray arms.
- Make sure that small items cannot fall through the holders in the baskets. Small items, e.g. lids, should therefore be placed in the cutlery basket.

## Application technology

---

- Items not suitable for dishwashers:**
- Wooden cutlery and cookware or items with wooden parts: these may discolor and fade. The glue used in these items is not dishwasher-proof and wooden handles may come loose after being washed in a dishwasher.
  - Craft items, antiques, valuable vases and decorative glassware: such items are not suitable for dishwashers.
  - Plastic items which are not heat resistant: the high temperatures in the dishwasher may cause them to melt or lose shape.
  - Copper, brass, tin and aluminum items: these may discolor or become matt.
  - Colors painted over a glaze: these may fade after a number of washes.
  - Delicate glassware and glassware containing lead crystal: clouding may occur over time.

- We recommend**
- When purchasing new cookware and cutlery, make sure they are dishwasher-proof.
  - Clouding may occur on glasses after frequent washing. If delicate glassware is washed in the dishwasher ensure that only a special glass-care program with very low temperatures (see program chart) is selected and that suitable detergent is used. This will reduce the risk of clouding.

**Please note:**

Silver and aluminum which has been in contact with foods containing sulfur can discolor.

 Aluminum components (e.g. grease filters) must not be cleaned with caustic alkaline commercial or industrial cleaning agents. These may damage the material, or in extreme cases, there is a risk of a severe explosive chemical reaction (such as an explosive oxygen-hydrogen gas reaction).



### Upper basket

Use the upper basket for small, lightweight and delicate items such as cups, saucers, glasses, dessert bowls etc. Light, heat resistant plastic items can also be loaded in the upper basket.

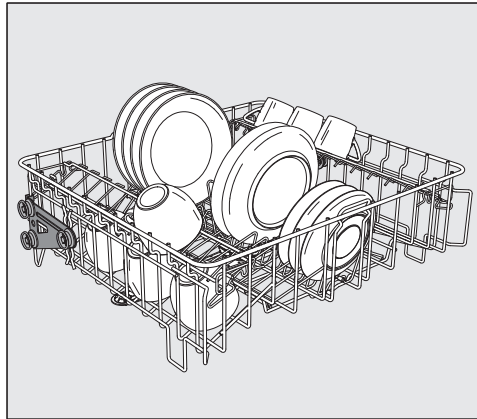

O 891 upper basket

With insert E 810 for e.g. 20 cups, 33 saucers or 17 dessert plates.

### Cup rack

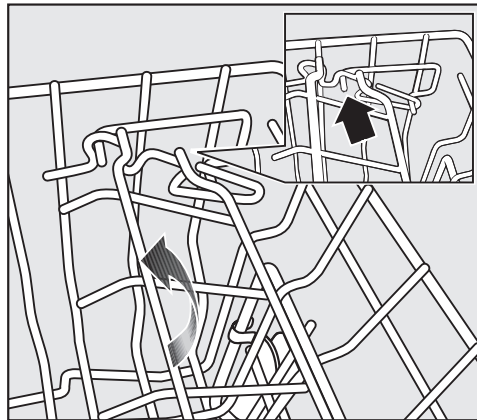

The cup rack can be set at two different widths so that it can also accommodate large cups.

- Pull the cup rack upwards and click it back into position at the required width.

### Adjusting the upper basket

In order to gain more space for taller pieces of cookware in the lower or upper basket, the upper basket can be adjusted in between two positions with 2" (5 cm) between each position.

- Pull the upper basket out.

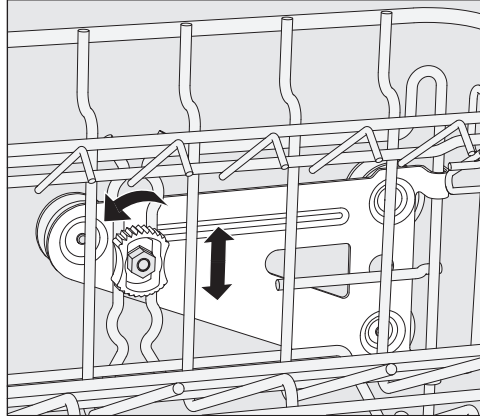

- Unscrew the fixing nuts on both sides.
- Lift or lower the basket into the desired position.
- Tighten the fixing nuts again.

⚠ The upper basket must be level in both positions.  
If the basket is not level, the water connection will be blocked.

⚠ When changing the height of the upper basket, always adjust the water connection accordingly before pushing the upper basket back in.

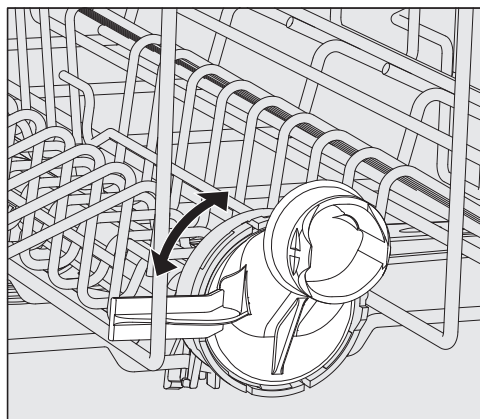

- Turn the upper basket water connection to the upper or lower position.  
The water connection must click audibly into place.

Depending on the setting of the upper basket, the following plate dimensions can be accommodated: Example upper basket O 891:

Upper basket in position	Upper basket plates Ø	Lower basket plate Ø
Upper	max. 5 1/8" (15 cm)	13" (33 cm) *
Lower	max. 7 7/8" (20 cm)	9 3/4" (25 cm)

\* Plate insert E 812 required in the lower basket.

### Lower basket

For larger and heavier items such as plates, serving platters, saucepans, bowls, etc.

Always place thin, delicate glassware in the lower basket using a suitable insert or basket.

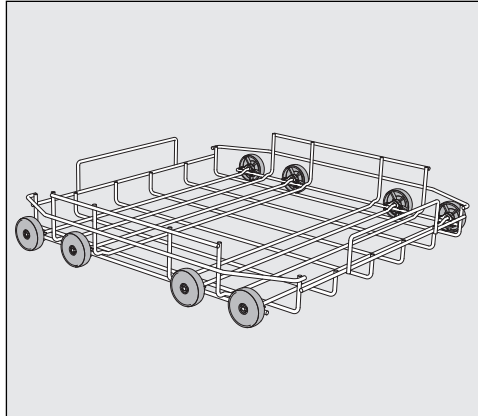

U 890 lower basket

For plastic trays, various inserts and cutlery inserts.

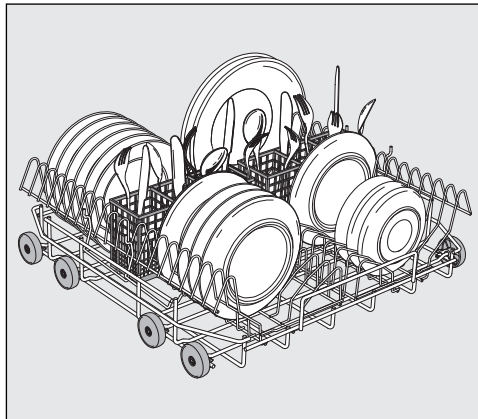

U 890 lower basket with 2 x E 816 inserts and 2 x E 165 cutlery inserts

16 plates with  $\text{Ø } 9 \frac{3}{4}$ " (25 cm) each and various cutlery can be loaded. Without the cutlery inserts, 19 plates with  $\text{Ø } 9 \frac{3}{4}$ " (25 cm) each can be loaded into E 816 inserts.

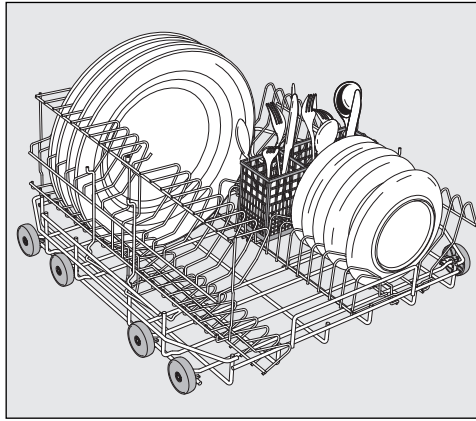

U 890 lower basket with an E 816 insert rotated by 90°

With the E 165 cutlery insert, 16 plates with Ø 13" (33 cm) each and various cutlery can be loaded. Without the cutlery insert, 19 plates with Ø 13" (33 cm) each can be loaded into the rotated E 816 insert.

### Use of plastic trays

The U 890 lower basket insert can be loaded with plastic trays measuring 19 3/4" x 19 3/4" (500 x 500 mm).

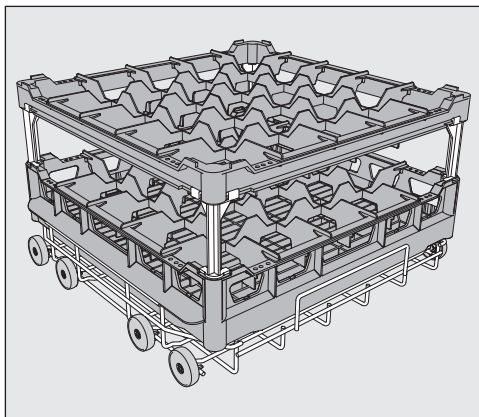

The special O 885 upper basket insert is required for loading plastic trays in the upper basket (max. loading height for items 5 1/8" (130 mm)).

The special U 876 lower basket insert is required for loading taller items in the lower basket.

The type, shape and size of the items to be washed will determine which basket combination to use.

For additional information on baskets please contact your Miele dealer or the Miele Service.

Examples: (lower baskets)

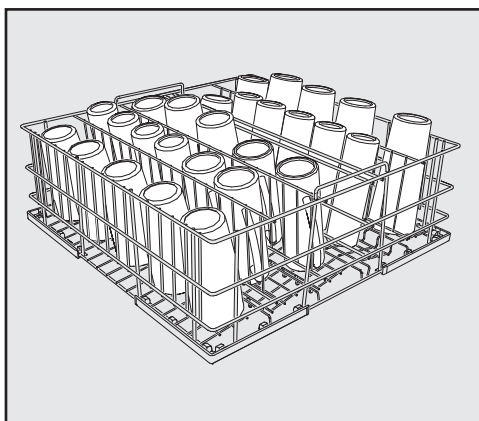

U 525 5-row wire basket

The wire basket can be used for glasses with a maximum diameter of 3 1/8" (8 cm).

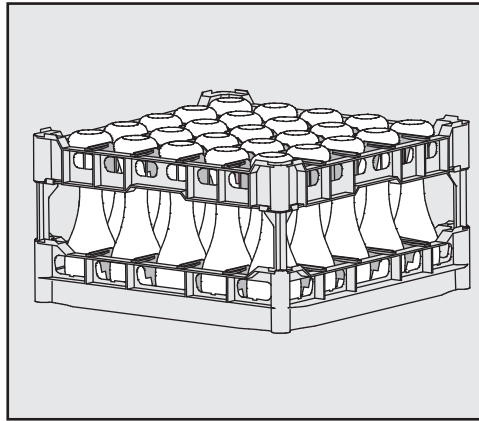

U 534 - U 537 plastic trays with compartments for different glass heights

In this example the plastic tray is connected to the top frame by long extenders. (for assembly in U 876 lower basket only)

### Assembling a plastic tray

The height of the base basket can be altered by fitting a top frame ① to the base ④ with long ② or short ③ extenders.

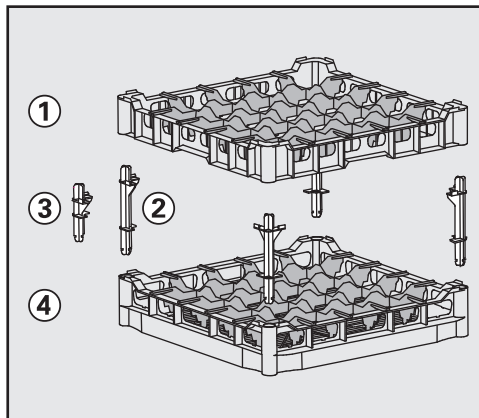

- Push all four extenders into the base basket ④.
- Press the top frame ① securely onto the extenders.

## Adding detergent

Only use detergent for commercial dishwashers.

The detergent can be dispensed in powder form via the powder detergent dispenser or in liquid form via the G 60 DOS module (Optional accessory - see "DOS module").

Never use detergent tablets.

The tabs do not dissolve completely during the short program run-times.

## Powder detergent

Only use powder detergent in the door dispenser compartment.

Add powder detergent to the detergent dispenser in the door before every wash program (except , Cold, Reactivation and Drain). Follow the tips on the next page.

- Add the appropriate amount of detergent to the dispenser according to the degree of soiling of the items to be washed (observe the quantities given in the "Program chart").

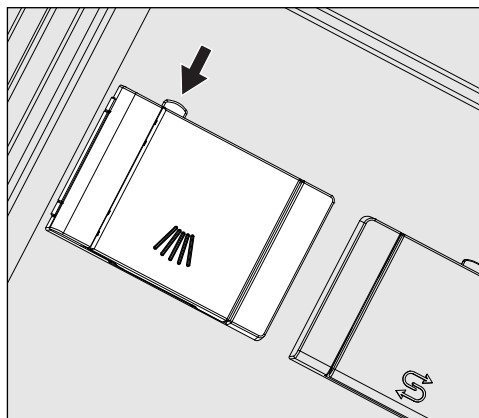

- Press the opening catch on the dispenser in the direction of the arrow. The flap will spring open to the left.

The cover will already be open after a completed wash program.

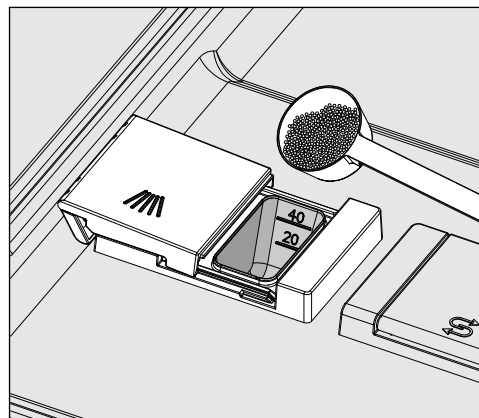

- Add the required amount of powder detergent and close the flap.



### Dispensing

- Always follow the recommendations of the detergent manufacturer.

There are markings to assist with dispensing: 20, 40. The marks indicate a level of approx. 20 or 40 ml (0.7 oz or 1.3 oz) when the door is open in the horizontal position. They also indicate the approx. level in grams (depending on the manufacturer and the coarseness of the agent).

The compartment holds a maximum of 60 ml (2 oz).

## DOS module

In addition to the internal dispensing systems, up to two additional external dispensing systems (DOS modules) can be connected for dispensing liquid process chemicals.

The DOS module comes with a separate installation manual.

For more information on Miele DOS modules, please contact your Miele dealer or Miele Service.

## Labelling of the siphons

The color coding of the siphons helps to ensure correct dispensing.

Miele use and recommend:

Red: for rinse aid

Blue: for detergent

## Refilling or changing containers

The DOS module is equipped with a level indicator which gives a message in the display when the level drops below the minimum.

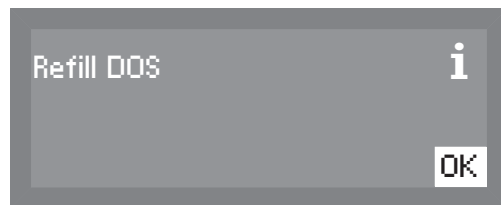

- Refill the appropriate process chemical at the end of a program as soon as the message appears in the display.
- Confirm the message with the *OK* button.

Refill the container in time to prevent the dispensing system being emptied completely.  
An empty dispensing system must be vented before starting the next program.

- Place the container on the open cabinet door or on a surface which is easy to clean.

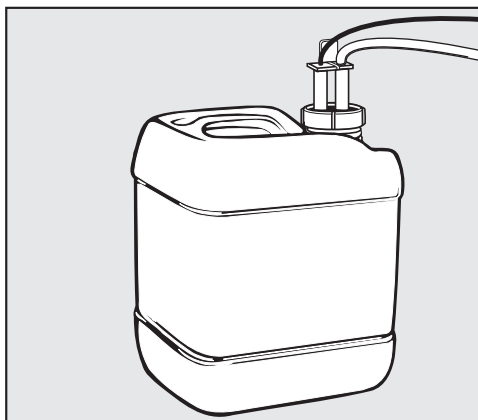

- Unscrew and remove the siphon. Place the siphon on the open cabinet door.
- Refill the container or replace it with a full one.

- Push the siphon into the opening of the container and screw it on tightly. Observe the color coding.
- Wipe up any spilled process chemical thoroughly.
- Place the container on the floor beside the dishwasher or in an adjacent cupboard.
- Vent the dispensing system if necessary.

To vent the system and adjust the dispensing amount, see "Additional settings, Additional functions."

### Checking consumption

Monitor the amount of process chemicals used by regularly checking the level in the container in order to detect any irregularities.

### Dispensing system maintenance

To ensure trouble-free operation, regular maintenance of the DOS module should be carried out at specified intervals only by Miele Service or an authorized Miele dealer.

The DOS G 60 module dispensing hoses must be replaced at 1 - 1 1/2 yearly intervals.

 Caution when handling liquid agents. They can contain irritant or corrosive ingredients.  
Follow the appropriate safety regulations.  
Safety goggles and gloves must be worn.

For cleaning specific types of soiling, and for information on the optimum detergents and additives to use for liquid dispensing, please contact Miele Service.

## Operation

### LEDs in the keypad

Light-emitting diodes that indicate the status of the dishwasher are set into the keypad.



Except for the *Start/Stop* button, which has a green LED in normal operation, all other LEDs light up yellow.

In the event of a fault the *Start/Stop* button flashes red.

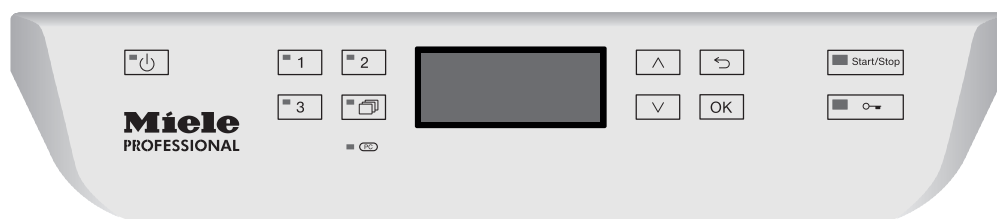
Keypad	LED	Status
⏻ button (On/Off)	<b>ON</b>	The dishwasher is turned on.
	<b>OFF</b>	The dishwasher is turned off.
Button 1-3 (program shortcut buttons)	<b>ON</b>	The respective program has been selected. At the end of the program, the LED will remain lit until a different program is selected.
	<b>OFF</b>	The program is not selected or the program settings are being selected.
📄 button (additional programs)	<b>ON</b>	A program was selected from the program list. At the end of the program, the LED will remain lit until a different program is selected.
	<b>OFF</b>	No program has been selected from the list or the program settings are being selected.
<i>Start/Stop</i> button	<b>ON</b>	A program is running.
	<b>FLASHES GREEN</b>	A program has been selected, but not yet started.
	<b>FLASHES RED</b>	A fault has occurred.
	<b>OFF</b>	A program has finished.
🔒 button (door but- ton)	<b>ON</b>	A program has been selected, but not yet started.
	<b>FLASHES</b>	A program is finished and the door is closed.
	<b>OFF</b>	A program is running.



## Activation

- Open the water faucet, if it is closed.
- Press the  button until the LED on the keypad lights up.
- Close the door (the LED for the  button will light up).

As soon as the dishwasher is ready for operation, the display changes to show the last selected program, e.g.:

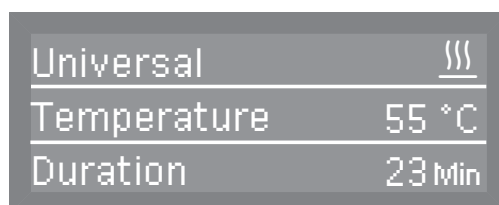

## Selecting a program

Choose your program according to the type of load and how dirty it is.

**Shortcut buttons** The most regularly used programs can be selected via shortcut buttons 1, 2 or 3. These can be adapted to suit individual needs (see "Additional Settings").

The first three programs from the Program chart are allocated to the shortcut buttons as the factory default.

- Select a program using the shortcut buttons.

The LED for the shortcut button will light up and the LED for the *Start/Stop* button will flash.

**Program list** Programs which cannot be selected via the shortcut buttons can be selected from the program list.

- Press the  button.

The following selection menu appears in the display

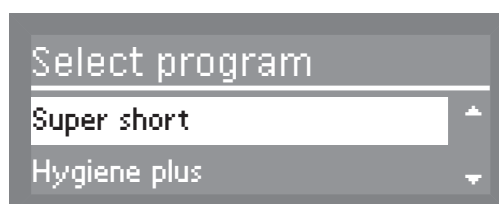

- Select the program you want using the  $\wedge$  and  $\vee$  buttons and confirm your choice using the *OK* button.

## Operation

---

The selected program will be shown in the display, e.g.:

Universal	
Temperature	55 °C
Duration	23 Min

The LED for the  button will light up and the LED for the *Start/Stop* button will flash.

Additional functions can be selected by pressing the *OK* button (see "Additional functions").

### Starting a program

- Press the *Start/Stop* button.

The LED for the *Start/Stop* button will light up and the LED for the  button will go out.

A program can no longer be changed after it has been started.  
A program can either be interrupted (see "Interrupting a program") or cancelled (see "Cancelling a program").

### Program cycle display

After the start of a program, the wash phase description and, for 10 seconds, Program running are shown in the display.

During the program cycle, the arrow buttons  $\wedge$  and  $\vee$  can be used to switch between the wash phase, the target temperature, and the actual temperature in the second line of the display.

The time remaining is shown in the third line of the display.

Universal	
Main wash 1	
Duration	23 Min

## Program end

After a program which has ended normally the LED for the *Start/Stop* button will turn off and the LED for the  button will flash. The message Program finished will appear in the bottom line of the display.

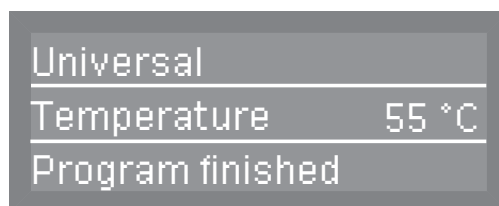

In addition to this a buzzer will also sound for approx. 3 seconds (factory default). To alter the buzzer tones see "Settings , Buzzer tones".

If drying assistance has been activated (see "Settings , Drying"), the door will automatically open a few centimeters.

If the turn-off function is activated, the dishwasher turns itself off after a short period of time.  
Press the  button to turn on.

## Deactivation

- Press the  button until the LED in the keypad turns off.

If the dishwasher is turned off, the time of day set appears in the display.

You can also alter the time of day display when the dishwasher is turned off (see "Settings, Time of day, Display").

## Unloading the dishwasher

Dishes tend to break and chip more easily when they are hot. Allow the dishes to cool until they are cool enough to handle before unloading them.

The dishes will cool much faster if you open the door when the program has ended.

First unload the lower basket, then the upper basket. This will prevent water drops from the upper basket falling onto the dishes in the lower basket.

### Interrupting a program

A program which is already running should only be interrupted if absolutely necessary, e.g. if the wash load is moving about significantly.

⚠ Caution! The wash load and the interior of the dishwasher may be hot.  
Danger of scalding and burning.

- Press the  button.

⚠ If the temperature in the wash cabinet is more than 158°F (70 °C), the warning *Wash cabinet too hot* will appear in the display.

- Confirm the message shown with the *OK* button.

The following will appear in the display:

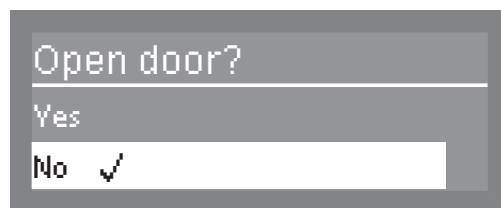

- Select *Yes* and confirm the entry with the *OK* button.

The program will only be cancelled when *Yes* is confirmed.  
If there is no additional input 20 seconds after the  button has been pressed, the display will revert to the program cycle.

The door will open and the following message will appear in the display:

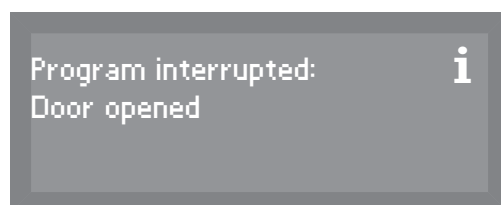

- Rearrange the items so that they are stable.
- Close the door.

The program will continue from the point at which it was interrupted.

The display will automatically revert to the program cycle.



## labelling Cancellling a program

Only cancel a program which has already started if absolutely necessary, e.g. if you want to change the program.

In the event of a fault, the program will be cancelled automatically.

 Caution! The wash load and the interior of the dishwasher may be hot.  
Danger of scalding and burning.

- Press the *Start/Stop* button.

The following will appear in the display:

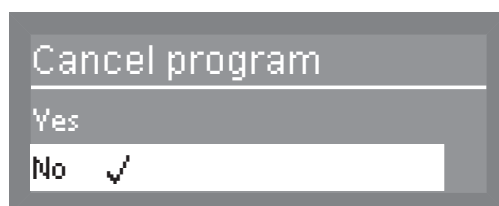

- Select *Yes* and confirm the entry with the *OK* button.

The program will only be cancelled when *Yes* is confirmed.  
If there is no additional input 20 seconds after the *Start/Stop* button has been pressed, the display will revert to the program cycle.

The following message appears in the display:

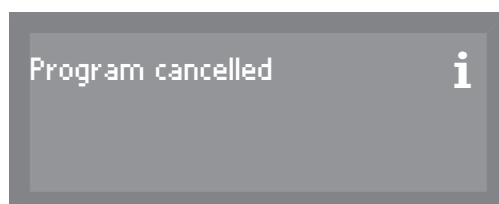

If you change the program and the detergent compartment flap is open, add more detergent as necessary.

## Program chart

Program	When to use	Powder detergent (if liquid detergent is <b>not</b> dispensed)
		<b>Follow the manufacturer's recommendations</b>
Short	"Quick program" for lightly soiled items with fresh, easily removed food residues.	20 - 30 g in the detergent dispenser
Universal	For normally soiled items.	20 - 30 g in the detergent dispenser
Intensive	For heavily soiled items.	20 - 30 g in the detergent dispenser
 Reactivation	Manual reactivation. This can be run to avoid being forced to run a reactivation program during busy periods.	
Rinse	Use for rinsing heavily soiled items and to prevent soiling from drying on the items. Also used for flushing salt out of the cabinet after refilling the salt container.	
Drain	For pumping away the rinse water when, for example, the program has been cancelled.	

## Program chart

Program cycle						
1. Pre-wash	2. Pre-wash	3. Main wash (1) / (2)	4. Interim rinse	5. Interim rinse	6. Final rinse (1) / (2)	7. Drying
X		X 151°F (66°C) 1 min		(X)	X 185°F (85°C) 1 min	(X)
X		X 151°F (66°C) 1 min	X	(X)	X 185°F (85°C) 1 min	(X)
X	X	X 151°F (66°C) 3 min	X	(X)	X 185°F (85°C) 1 min	(X)
Reactivation cycle			X			
	X					

X = sections included in a program

(X) = optional sections which can be selected (see "Additional settings, Additional functions")

(1) Temperature range 86 - 185°F (30 - 85 °C) (see "Additional settings, additional functions").

(2) Holding time range from 0 - 10 minutes (see "Additional settings, Additional functions").

## Additional functions

### Delay start

The start time of a program can be delayed. A delay start time of between 1 minute and 24 hours can be selected.

Delay start must be turned on in the Settings menu (see "Settings ▾, Delay start").

If delay start has been turned off, it will not be visible when additional functions are called up.

When using the delay start function, make sure that the detergent compartment is dry before adding detergent. Wipe dry with a cloth if necessary.

If the compartment is wet, detergent can become lumpy and stick to the dispenser, with the result that it is not fully dispensed.

### Setting the start time

- Turn the dishwasher on with the  button.
- Select the program you require (see "Operation, Selecting a program"). The LED on the *Start/Stop* button will flash.
- Press the *OK* button.
- Select Delay start and confirm the entry with the *OK* button.

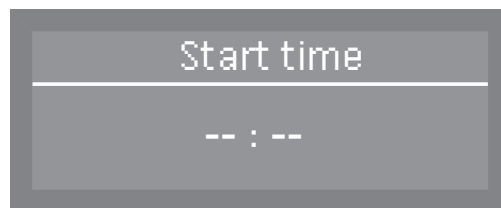

- Use the arrow buttons  $\wedge$  (higher) and  $\vee$  (lower) to set the hours and minutes and confirm each entry using the *OK* button.
- When you have entered the start time, press the *Start/Stop* button.

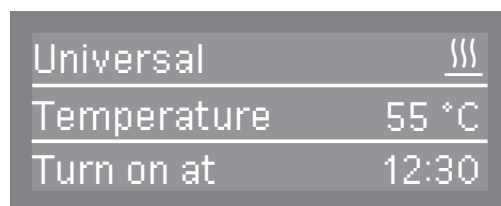

The selected program, along with the temperature and start time, will then be displayed.

To cancel a set delay start before it has started, turn the dishwasher off using the  button.

### Drying assistance

To achieve better drying results, the dishwasher door will automatically open a few centimeters at the end of the program.

This function cannot be activated for all programs (see "Program chart").

Drying assistance can be activated or deactivated for the selected program, even if it is turned on or off permanently under "Settings ▾, Drying".

- Turn the dishwasher on with the  button.
- Select the program you require (see "Operation, Selecting a program"). The LED on the *Start/Stop* button will flash.
- Press the *OK* button.
- Select Drying assistance and confirm the entry with the *OK* button.

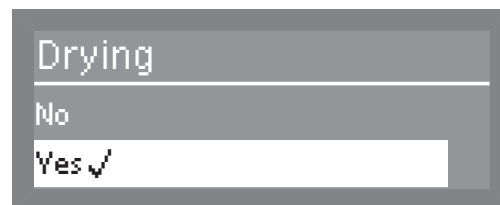

- No  
Drying assistance is deactivated for the selected program.
- Yes  
Drying assistance is activated for the selected program.

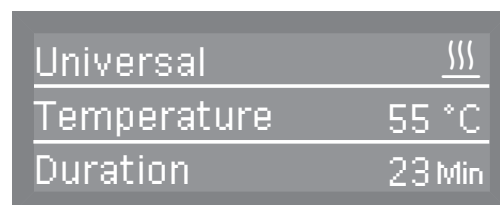



If drying assistance has been activated, the drying symbol  will appear in the display to the right of the program name.

If the wash cabinet temperature after the final wash phase is higher than 153°F (67°C), an active cooling phase takes place before the end of the program. The program will only end when the temperature is lower than 153°F (67°C).

An audible tone sounds, *Program finished* appears in the display and the door automatically opens a few centimeters.

### Accessing the "Settings " menu

To open the settings menu:

- Turn the dishwasher off.
- Press and hold the  button and turn the dishwasher back on using the  button.

After that, the display will show the following, for example:

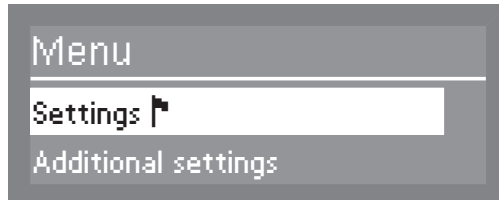

If the  button is pressed in this menu, the dishwasher will revert to normal operation.

- Select the Settings  option and open the menu for this by pressing the *OK* button.

### Options in the Settings menu

- Delay start  
Turn delay start on or off (see "Delay start")
- Drying  
Turn drying assistance on or off permanently and adjust drying the time (see "Drying").
- Language   
Select the operating language (see "Set the language")
- DOS priming (Option is only visible if a DOS module is activated)  
Vent dispensing system (see "DOS venting")
- Date  
Set the date and date format (see "Set the date")
- Time of day  
Set the time and clock format (see "Time of day")
- Volume  
Set the volume of keypad and buzzer tones (see "Buzzer tones")

## Menu structure

The factory defaults for the menu structure are shown.

Menu	1. Submenu	2. Submenu
1. Delay start	No ✓ Yes	
2. Drying	No Yes ✓	
3. Language	German ✓ English (US) etc.	
4. DOS venting	DOS1 DOS4	
5. Date	Date format  Set	DD:MM:YY ✓ MM:DD:YY
6. Time of day	Set  Display   Clock format	Setting the clock Do not display ✓ On "On" for 60 seconds 12 h 24 h ✓
7. Volume	Keypad tone Buzzer tones	Program end Warning

### Delay start

You can select whether delay start appears in the Additional Functions menu or not.

Selecting **No** will remove delay start from the Additional Functions menu for operators.

To be able to delay the start of a program, **Yes** must be selected in order for it to be displayed in Additional Functions.

To set the start time see "Additional functions, Delay start".

- Select the Settings  menu.
- Select **Delay start** and confirm the entry with the *OK* button.

The following options are available:



- No  
Delay start is turned off and therefore not visible as an additional function.
- Yes  
Delay start is turned on.
- Select the option you want and confirm your choice with the *OK* button.



## Drying

You can turn assisted drying on or off for all programs that support this function.

In Additional Functions, you can select or deselect drying for individual programs (see Additional functions, "Drying assistance").

- Select the Settings  menu.
- Select Drying and confirm the entry with the OK button.

The following options are available:





- No  
Drying is turned off.
- Yes  
Drying is turned on for those programs which support drying assistance.

### Setting the language

The language set will be used in the display.

The flag  after the word "Language" acts as a guide if a language which you do not understand has already been set. If this is the case, keep selecting the option which has a flag after it until you reach the "Language" submenu.

- Select the Settings  menu.
- Select Language  and confirm the entry with the *OK* button.

A list will appear in the display with all the languages available in the system.



- Use the  $\wedge$  and  $\vee$  arrow buttons to select the language you want and confirm your choice using the *OK* button.

## Venting DOS modules

This option is only visible when a DOS module is connected.

The dispensing system for liquid agents can only dispense reliably if the system has been purged of air.

The DOS system must be vented:

- if it is being used for the first time,
- if the liquid detergent or rinse aid reservoir was not refilled in time and the DOS system was emptied.

 To avoid damage to the dispensing system, make sure before venting that the containers for detergent and rinse aid are sufficiently filled and the dispensing siphons are screwed securely to the containers.

- Select the Settings  menu.
- Select DOS priming and confirm the entry with the *OK* button.



- Select the dispensing system to be vented using the  $\wedge$  and  $\vee$  arrows and confirm your choice with the *OK* button.

The dishwasher will then start to vent the selected dispensing system automatically. As soon as this is completed, Dispensing system successfully primed will appear in the display.

- Confirm the message with the *OK* button.

## Setting the date

- Select the Settings  menu.
- Select Date and confirm the entry with the *OK* button.

In the following menu, you can choose between:

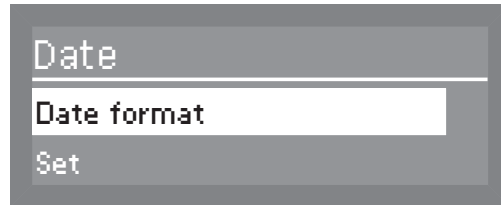

- Date format  
This option offers two variations for date format.
- Set  
This option is used to set the date in the selected format.

## Date format

- Select Date format and confirm the entry with the *OK* button.

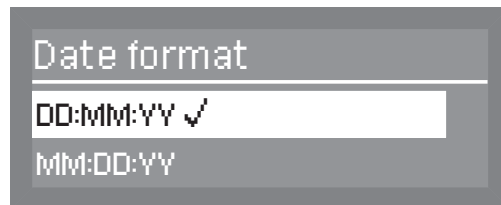

DD stands for day  
MM stands for month  
YY stands for year

- Select the date format you want and confirm your choice with the *OK* button.

## Set

- Select Set and confirm the entry with the *OK* button.



- Use the arrow buttons  $\wedge$  (higher) and  $\vee$  (lower) to set the day, month and year and confirm each entry using the *OK* button.

When day, month and year have been set, the display reverts automatically to the Date menu.

## Setting the clock

- Select the Settings  menu.
- Select Time of day and confirm the entry with the *OK* button.

In the following menu, you can choose between:

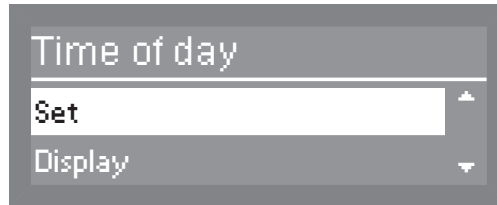

- Set  
Set the time of day.
- Display  
Time of day displayed when the dishwasher is turned off.
- Time format  
Set the clock format.

The dishwasher does not automatically adjust between summer and winter time. This must be done manually by the operator as required.

### Set

- Select Set and confirm the entry with the *OK* button.



- Use the arrow buttons  $\wedge$  (higher) and  $\vee$  (lower) to set the hours and minutes and confirm each entry using the *OK* button.

When hours and minutes have been set, the display reverts automatically to the Time of day menu.

## Display

If required, the time of day can be displayed when the dishwasher is turned off.

- Select **Display** and confirm the entry with the *OK* button.

The following options are available:



- Do not display  
Time of day is not displayed.
- On  
Time of day is constantly displayed.
- On for 60 seconds  
Time of day is displayed for 60 seconds after turning off.

Select the setting you want and confirm your choice with the *OK* button.

## Clock format

- Select **Time format** and confirm the entry with the *OK* button.

The following options are available for clock format in the display:

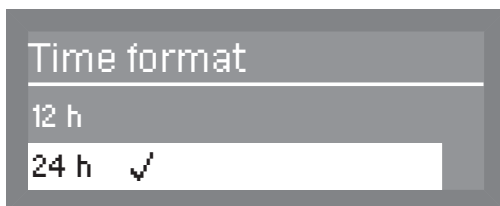

- 12 h (am / pm)
- 24 h
- Select the format you want and confirm your choice with the *OK* button.

## Regulating the volume

The dishwasher has audible tones which sound when buttons on the keypad are pressed, at the end of a program, and when there are system messages.

- Select the Settings  menu.
- Select Volume and confirm the entry with the *OK* button.

The following options are available:

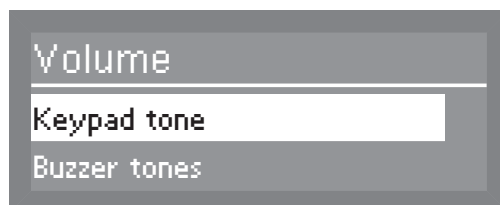

- Keypad tone  
Set the keypad volume.
- Buzzer tones  
Set the volume for program end and for warning messages.

### Keypad tone

- Select Keypad tone and confirm the entry with the *OK* button.
- Set the volume you want (see "Setting the volume") and confirm your choice with the *OK* button.

### Buzzer tones

- Select Buzzer tones and confirm the entry with the *OK* button.

The following options are available:

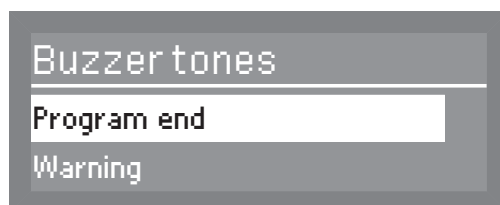

- Program end  
Set the buzzer tone for the end of the program.
  - Warning  
Set the buzzer tone for warning messages.
- Select the appropriate option and confirm your choice with the *OK* button.
  - Set the volume you want (see "Setting the volume") and confirm your choice with the *OK* button.

### Setting the volume

The volume is always set in the same way. The display is also similar, e.g.:

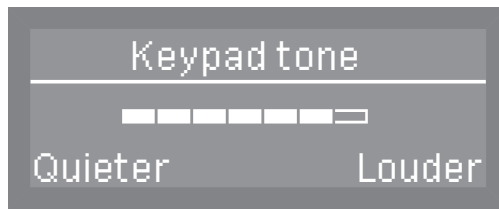

- Set the volume using the arrow buttons  $\wedge$  (louder) and  $\vee$  (quieter). The volume level is represented by a bar graph. On the lowest setting the tone is turned off.
- Confirm the volume set with the *OK* button.

If there is no additional input for approx. 15 seconds, the display will revert to the previous menu without saving the setting.



### Opening the "Additional settings" menu

To open the "Additional settings" menu:

- Turn the dishwasher off.
- Press and hold the ↵ button and turn the dishwasher back on using the ⏻ button.

After that, the display will show the following, for example:



If the ↵ button is pressed in this menu, the dishwasher will revert to normal operation.

- Select Additional settings and press *OK* to open the relevant menu.

### Options in the Additional Settings menu

This menu can be protected with a PIN code (see "Additional settings, Code").

- Code  
PIN code assignment and settings (see "Code")
- Log book  
Displays consumption levels for agents used and operating hours (see "Log book")
- Temperature unit  
Setting of the temperature unit between °C and °F (see "Temperature unit")
- Move program  
Programs can be allocated to the shortcut buttons (see "Move program")
- Additional functions  
Adaptation of program parameters such as water intake, interim rinses, temperatures, and holding times, as well as detergent concentration levels for the DOS modules (see "Additional functions")
- Release program  
Determination of the visibility of individual programs on the display (see "Program release")
- Water hardness  
Setting of the water hardness level (see "Water hardness" and "Water softener")
- Display view  
Setting of the display between the target and actual temperatures (see "Display view")

## Additional settings

---

- Display  
Adjustment of the display contrast and brightness (see "Display")
- Switch off after  
Automatic switch-off can be activated or deactivated (see "Switch off after")
- Factory default  
Reset of all parameters to the factory default settings (see "Factory default")
- Software version  
Display of the software version (see "Software version")

### Menu structure

The factory defaults for the menu structure are shown.

Menu	1. Submenu	2. Submenu	3. Submenu
1. PIN code	Release  Change PIN code	Additional settings Enter PIN code	Yes ✓ Block
2. Log book	Consumption: water Consumption: detergent Consumption: rinse aid Operating hours Program cycles Service interval		
3. Temperature unit	°C ✓ °F		
4. Move program	1. Short 2. Universal 3. Intensive etc.		
5. Additional functions	Reset  Increased water level  Interim rinse  Dispensing systems    Temperature / time	Yes No ✓   Yes No ✓ DOS2 rinse aid DOS1 DOS4  Short Universal Intensive etc.	Active Inactive DOS venting Concentration Change name  Reset Main wash 1 Final rinse 1
6. Program release	All ✓ Selection	<input checked="" type="checkbox"/> Short <input checked="" type="checkbox"/> Universal etc. Accept	
7. Water hardness	Enter hardness level		

## Additional settings

Menu	1. Submenu	2. Submenu	3. Submenu
8. Display view	Actual temperature Target temperature ✓		
9. Display	Contrast Brightness	Set the contrast Set the brightness	
10. Switch off after	Yes ✓ No	Set the time	
11. Factory default	Reset	No ✓ Program settings only All settings	
12. Software version	EB Id: XXXX EGL Id: XXXX EZL Id: XXXX EFU Id: XXXX		

### CODE

A PIN code can be used to prevent unauthorized access to various functions and system settings on the dishwasher.

- Select the Additional settings menu.
- Select Code and press *OK* to open the relevant menu.
  - Release  
Restrict access to the Additional settings menu to users with administrative rights only, or allow access to all users.
  - Change code  
Set a new PIN code.

### Release

- Select the Release option and confirm your choice with the *OK* button.
- Select Additional settings and confirm the entry with the *OK* button.

The following settings are available:



- Yes  
The menu is available to all users.
- Block  
The menu can only be accessed by using a PIN code.

A tick ✓ indicates the current status.

- Select the appropriate option and confirm your choice with the *OK* button.

### Changing the PIN code

- Select the Change code option and confirm your choice with the *OK* button.
- First enter the current PIN code (see "Enter code").
- Then enter your new PIN code.
- The PIN code is saved to memory once you have confirmed the last digit.

## Additional settings

---

### Enter PIN code

If in the Release menu you have selected the Block option, or if you have set the Additional settings menu up for access via a PIN code, you have to enter a PIN code.

Settings within the Additional settings menu can then only be changed by people with administration rights.

The PIN code is set at the factory to 8 0 0 0 if access in Additional settings is blocked.

In this instance, the display will show the following message:



- Use the  $\wedge$  and  $\vee$  arrow buttons to enter the numerical values and confirm each one with the *OK* button.

Each press of the *OK* button takes the highlighting to the next input position automatically.

Each digit entered is replaced by an asterisk (\*).

The protected settings are released once all digits have been correctly entered.

If the PIN code is entered incorrectly, the following message will appear in the display:

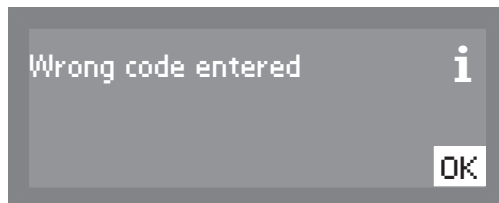

- Confirm the message with the *OK* button.

The display will then revert to the input menu.

### Log book

The dishwasher controls measure the consumption levels for water, detergent and rinse aid. They also calculate the number of hours the dishwasher has been run and the number of programs that have been run and measure the service intervals.

- Select the Additional settings menu.
- Select Log book and press *OK* to open the relevant menu.

The following options are available:

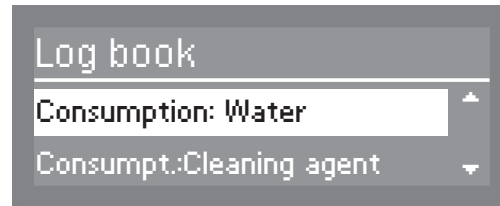

- Consumption: Water  
Display of the total amount of water used in liters
  - Consumpt.:Cleaning agent  
Display of the total amount of detergent used in liters (only for dishwashers using a DOS module)
  - Consumpt.: Rinsing aid  
Display the total amount of rinse aid used in liters
  - Operating hours  
Display of the total number of operating hours
  - Wash programs  
Display of the total number of program cycles
  - Service interval  
Display of the date when the next service is due
- Select the option you want and confirm your choice with the *OK* button.

The value will then be displayed.

Pressing the *OK* button takes you to the next level.

## Additional settings

---

### Temperature unit

The temperature can be shown in the display in degrees Celsius or degrees Fahrenheit.

- Select the *Additional settings* menu.
- Select *Temperature unit* and confirm the entry with the *OK* button.

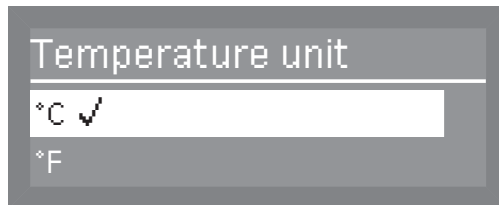

- °C  
The temperature is displayed in degrees Celsius
  - °F  
The temperature is displayed in degrees Fahrenheit
- Use the  $\wedge$  and  $\vee$  arrows to select the option you want and confirm your choice with the *OK* button.



### Move program

You can change the order of the programs and therefore also the allocation of the shortcut buttons.

You can move the programs you use most frequently to program places 1-3. These are then automatically allocated to the shortcut buttons.

- Select the Additional settings menu.
- Select Move program and confirm the entry with the *OK* button.

### Shortcut buttons

Programs are displayed in their current order.

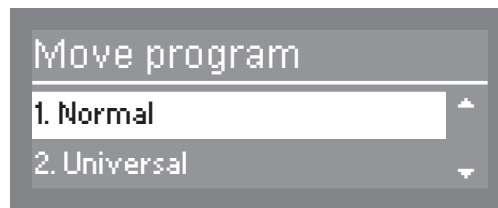

- Use the  $\wedge$  and  $\vee$  buttons to select a program from the list that you wish to move, and then confirm your choice with the *OK* button.

The program you select will be marked with a tick ✓.



- Use the  $\wedge$  and  $\vee$  buttons to select the position you want to move it to and confirm your choice with the *OK* button.

Moving a program forwards moves the programs after it down a position.

Moving a program to the end of the list moves the programs in front of it up a position.

## Additional settings

---

### Additional functions

It is possible to adapt individual parameters to tailor program cycles to particular types of soiling and to optimize the cleaning result.

- Select the **Additional settings** menu.
- Select **Additional functions** and press **OK** to open the relevant menu.

In the following menu, you can choose between:

- **Reset**  
Reset of all parameters changed in Additional Functions to their default settings
- **Increased water level**  
Increase in the amount of water used in all wash programs
- **Interim rinse**  
Introduction of an interim rinse to all programs that support this feature (see "Program chart")
- **Dispensing system**  
Venting of the dispensing systems and naming of the DOS modules
- **Temperature / Time**  
Change in the temperature and holding time for the main wash and final rinse stages of a wash program

### Reset

- Select the **Reset** option and confirm your choice with the **OK** button.



- Select the **Yes** option and confirm your choice with the **OK** button.

All parameters that have been changed under "Additional functions" will be reset to the factory default setting.

### Increased water level

- Select the Increased water level option and confirm your choice with the *OK* button.

The amount of water is shown in liters and can be increased in 0.5 liter increments up to 1.5 liters.



- Use the arrow buttons  $\wedge$  (higher) and  $\vee$  (lower) to select the amount of water you want and confirm your choice with the *OK* button.

### Interim rinse

- Select the Interim rinse option and confirm your choice with the *OK* button.

The following options are available:

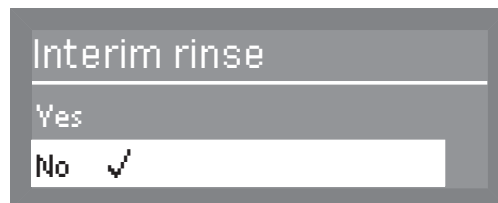

– Yes

The additional interim rinse is activated.

– No

The additional interim rinse is not activated.

- Select the option you want and confirm your choice with the *OK* button.

## Additional settings

---

### DOS dispensing systems

- Select the Dispensing system option and confirm your choice with the *OK* button.

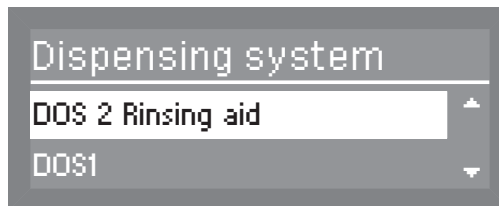

- Select the dispensing system you want and confirm your choice with the *OK* button.

The following settings are available:



- Active  
The dispensing system is activated.
- Inactive  
The dispensing system is not activated.
- DOS priming  
Venting of the dispensing system to ensure reliable dispensing.
- Concentration  
The concentration level of detergent and/or rinse aid can be set to suit requirements.
- Change name  
The name of the dispensing system can be changed.

With DOS 2 Rinsing aid, the only option displayed is Concentration.

With DOS1 and DOS4, the options DOS priming, Concentration and Change name are only visible if Active has been selected.

### DOS venting

⚠ To avoid damage to the dispensing system, make sure before venting that the containers for detergent and rinse aid are sufficiently filled and the dispensing siphons are screwed securely to the containers.

- Select DOS priming and confirm the entry with the *OK* button.

The dishwasher will now start the automatic venting process of the dispensing system.

Dispensing system DOS priming will appear in the display.

As soon as the process has finished, Dispensing system successfully primed will appear in the display.

- Confirm the message with the *OK* button.

### Setting the DOS concentration level

Please observe dispensing recommendations made by the manufacturer of the agent.

- Select Concentration and confirm the entry with the *OK* button.

Concentration levels are given as a percentage and can be set between 0.01 and 2.00%.

The concentration level set then applies to all programs.

Display for DOS1:

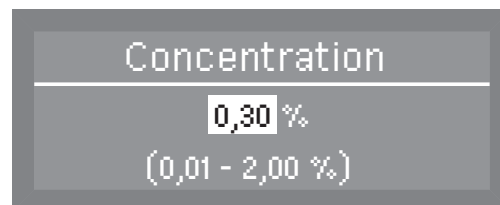

If a DOS G 60 module is connected to the dishwasher, the factory set concentration level set must be reduced by half.

Display for DOS2 rinse aid and DOS4:

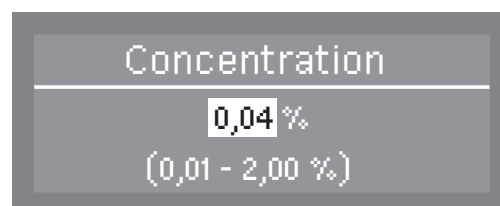

- Use the arrow buttons  $\wedge$  (higher)  $\vee$  (lower) to set the concentration level you want and confirm your choice with the *OK* button.

## Additional settings

---

Changing a DOS name

- Select Change name and confirm the entry with the *OK* button.

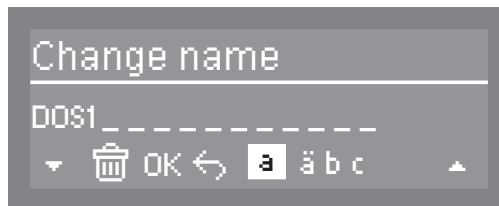

The current name is shown on the second line of the display. This can be changed using the options shown in the bottom line.

DOS is a set part of the name and cannot be changed.

The top line shows which option has been selected.

- Navigate using the arrow buttons to shift the cursor to the option required:  $\wedge$  (moves to the left) and  $\vee$  (moves to the right).
- Confirm each option individually with the *OK* button.

The following options are available:

- Letters from A - Z;  
each new word will start with a capital letter.
- Numbers from 0 - 9
- Space characters
- Use the  symbol to delete the last position in the name displayed.
- Select *OK* to save the name.
- If you do not want to save the name you have given, press the  $\curvearrowright$  symbol.

### Temperature / time

The temperature and holding time for the main wash and final rinse phases can be altered in some programs (see "Program chart").

- Select Temperature / Time and confirm the entry with the *OK* button.

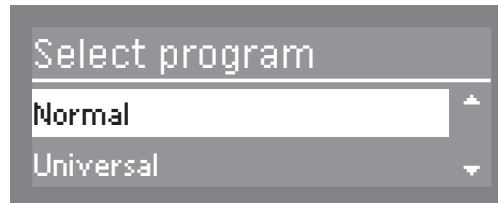

The following options are available:



- Reset  
This resets values changed in a program back to their factory default settings.
- Main wash 1  
This is used to adapt the temperature and the holding time in the main wash.
- Final rinse 1  
This is used to adapt the temperature and the holding time in the final rinse.

## Additional settings

---

**Main wash / Final rinse** The procedure for altering settings in Main wash 1 and Final rinse 1 is the same. The display also looks similar.

- Select the Main wash 1 or Final rinse 1 option and confirm the entry with the *OK* button.

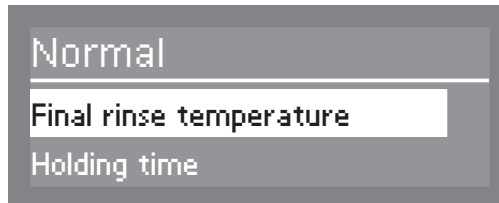

- Select the wash program you want and confirm your choice with the *OK* button.

The following settings are available:

- Temperature / Final rinse temp.  
The temperature for the main wash or the final rinse can be changed.
- Holding time  
The temperature holding time can be changed.

**Final rinse temperature**

- Select Temperature or Final rinse temp. and confirm your choice with the *OK* button.

The temperature for the main wash or the final rinse can be set from 86 to 185°F (30 to 85°C) in 1° increments.

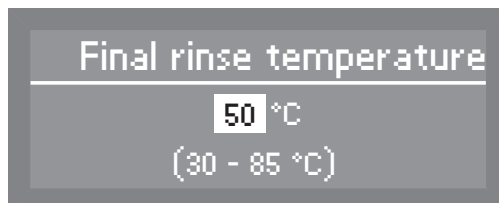

- Use the arrow buttons  $\wedge$  (higher)  $\vee$  (lower) to set the temperature you want and confirm your choice with the *OK* button.



### Holding time

- Select Holding time and confirm the entry with the *OK* button.

The holding time is set in minutes and can be set between 0 and 10 minutes in 1 minute increments.



- Use the arrow buttons  $\wedge$  (higher)  $\vee$  (lower) to set the holding time you want and confirm your choice with the *OK* button.

## Additional settings

---

### Program release

Individual programs can be blocked so that they cannot be used. All programs are released for use as default.

- Select the Additional settings menu.

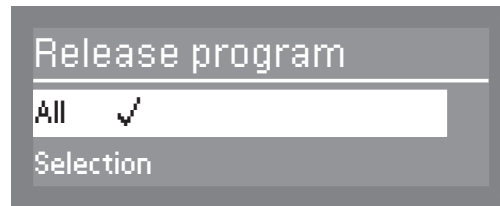

- Select Release program and press *OK* to open the relevant menu.

The following settings are available:

- All  
All programs are released for use.
- Selection  
Selection possibility for determining which individual programs can be blocked.

### Blocking programs

- Select Selection and confirm the entry with the *OK* button.

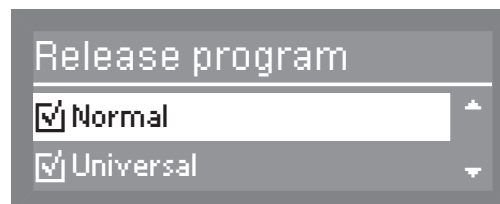

- Select the programs that you want to block and press the *OK* button.

The tick ✓ will be removed from the box  and the program can then not be used.

- To save your selection, select *Accept* at the end of the program list and confirm your choice with the *OK* button.

### Water hardness

In order to achieve good cleaning results, the dishwasher needs to operate with soft (low in calcium deposits) water. Hard water results in a build-up of calcium deposits on cookware and in the dishwasher. Water with a hardness level higher than 4 °dH needs to be softened. This takes place automatically in the integrated water softener. The water softener in the dishwasher is suitable for a water hardness level of up to 70 °dH (12.6 mmol/l).

The water softener in the dishwasher has to be set to the hardness level of your water supply.

- Your local water supplier can tell you the water hardness level in your area.
- Where the water hardness fluctuates (e.g. 16-28 gpg / 15-27°d), always program the dishwasher to the higher value (in this example, 28 gpg / 27°d).

If the hardness of your water constantly lies under 4 gpg (4 °dH), no salt must be filled in the water softener.

It is useful to know your water hardness so that you can provide the service technician with this information in the event of any service calls.

Enter the water hardness below:

\_\_\_\_\_ gpg (°dH)

- Select the Additional settings menu.
- Select Water hardness and confirm the entry with the OK button.

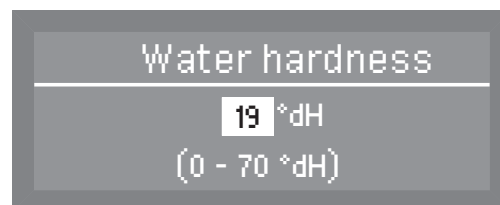

The factory default for the water softener is set to a hardness of 20 gpg (19°dH).

When making the setting, please observe the following table.

- Use the arrow buttons  $\wedge$  (higher) and  $\vee$  (lower) to set the water hardness required and confirm your entry using the OK button.

## Additional settings

Settings table

°dH	gpg	mmol/l	Display
1	1	0.2	<b>1</b>
2	2	0.4	<b>2</b>
3	3	0.5	<b>3</b>
4	4	0.7	<b>4</b>
5	5	0.9	<b>5</b>
6	6	1.1	<b>6</b>
7	7	1.3	<b>7</b>
8	8	1.4	<b>8</b>
9	9	1.6	<b>9</b>
10	10	1.8	<b>10</b>
11	11	2.0	<b>11</b>
12	12	2.2	<b>12</b>
13	13	2.3	<b>13</b>
14	14	2.5	<b>14</b>
15	15	2.7	<b>15</b>
16	16	2.9	<b>16</b>
17	17	3.1	<b>17</b>
18	18	3.2	<b>18</b>
<b>19</b>	<b>19</b>	<b>3.4</b>	<b>19 *)</b>
20	20	3.6	<b>20</b>
21	21	3.8	<b>21</b>
22	22	4.0	<b>22</b>
23	23	4.1	<b>23</b>
24	24	4.3	<b>24</b>
25	25	4.5	<b>25</b>
26	26	4.7	<b>26</b>
27	27	4.9	<b>27</b>
28	28	5.0	<b>28</b>
29	29	5.2	<b>29</b>
30	30	5.4	<b>30</b>
31	31	5.6	<b>31</b>
32	32	5.8	<b>32</b>
33	33	5.9	<b>33</b>
34	34	6.1	<b>34</b>
35	35	6.3	<b>35</b>

°dH	gpg	mmol/l	Display
36	36	6.5	<b>36</b>
37	37	6.7	<b>37</b>
38	38	6.8	<b>38</b>
39	39	7.0	<b>39</b>
40	40	7.2	<b>40</b>
41	41	7.4	<b>41</b>
42	42	7.6	<b>42</b>
43	43	7.7	<b>43</b>
44	44	7.9	<b>44</b>
45	45	8.1	<b>45</b>
46	46	8.3	<b>46</b>
47	47	8.5	<b>47</b>
48	48	8.6	<b>48</b>
49	49	8.8	<b>49</b>
50	50	9.0	<b>50</b>
51	51	9.2	<b>51</b>
52	52	9.4	<b>52</b>
53	53	9.5	<b>53</b>
54	54	9.7	<b>54</b>
55	55	9.9	<b>55</b>
56	56	10.1	<b>56</b>
57	57	10.3	<b>57</b>
58	58	10.4	<b>58</b>
59	59	10.6	<b>59</b>
60	60	10.8	<b>60</b>
61	61	11.0	<b>61</b>
62	62	11.2	<b>62</b>
63	63	11.3	<b>63</b>
64	64	11.5	<b>64</b>
65	65	11.7	<b>65</b>
66	66	11.9	<b>66</b>
67	67	12.1	<b>67</b>
68	68	12.2	<b>68</b>
69	69	12.4	<b>69</b>
70	70	12.6	<b>70</b>

\*) Factory default setting

### Display view

During a program, the actual or target temperature can be shown in the second line of the display.

- Select the Additional settings menu.

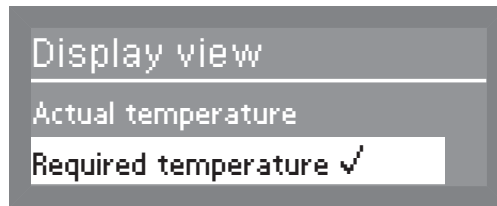

- Select Display view and press *OK* to open the relevant menu.

The following settings are available:

- Actual temperature  
Display of the actual temperature during a program (this value will vary during the course of the program).
  - Required temperature  
Specification of the set temperature for the main wash or the final rinse program block  
(the maximum value is displayed as a static value. It will change from one program block to the next).
- Select the option you want and confirm your choice with the *OK* button.

## Additional settings

---

### Display

The display menu can be used for altering the display contrast and brightness.

- Select the Additional settings menu.

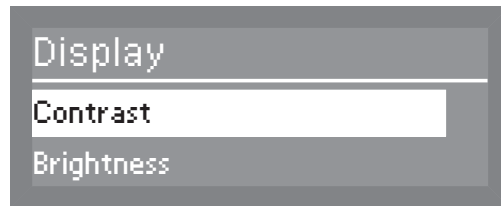

- Select Display and press *OK* to open the relevant menu.

The following settings are available:

- Contrast  
Set the contrast.
- Brightness  
Set the brightness.

### Contrast

- Select the Contrast option and confirm your choice with the *OK* button.

The contrast range is shown as a bar graph in the display.



- Use the arrow buttons  $\wedge$  (higher)  $\vee$  (lower) to set the contrast you want and confirm your choice with the *OK* button.

### Brightness

- Select the *Brightness* option and confirm your choice with the *OK* button.

The brightness range is shown as a bar graph in the display.



- Use the arrow buttons  $\wedge$  (brighter)  $\vee$  (darker) to set the brightness you want and confirm your choice with the *OK* button.

## Additional settings

---

### Switch off after

When not in use, the dishwasher will turn itself off to save energy.

- Select the Additional settings menu.
- Select Switch off after and press *OK* to open the relevant menu.

The following options are available:



- Yes  
The "Switch Off After" option is active and you can specify a duration after which the appliance switches off.
- No  
The "Switch Off After" option is not active.

### Setting the "switch off after" duration

- Select the Yes option and confirm your choice with the *OK* button.

The "switch off after" duration is set to 60 minutes ex works. It can be adjusted in 5 minute increments from 5 to 60 minutes.

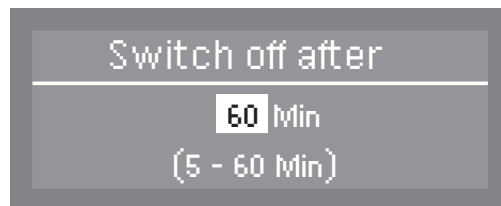

- Use the arrow buttons  $\wedge$  (higher)  $\vee$  (lower) to set the "switch off after" duration and confirm your choice with the *OK* button.



### Factory default setting

The factory default setting can be used to reset all changed parameters in the dishwasher back to their default settings or just values that have been changed for programs.

- Select the Additional settings menu.

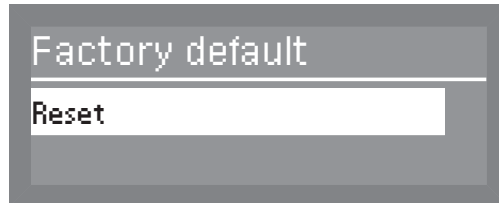

- Select Factory default and press *OK* to open the relevant menu.

The following options are available:

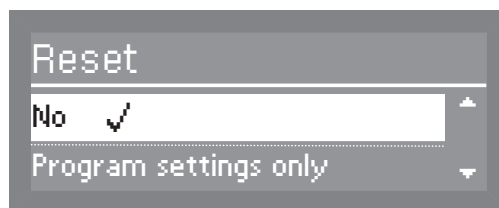

- No  
Altered parameters will not be reset to their default settings.
  - Program settings only  
Only values that have been altered in programs will be reset to their default settings.
  - All settings  
All parameters that have been altered in the dishwasher will be reset to their default settings.
- Select the option you want and confirm your choice with the *OK* button.

## Additional settings

---

### Software version

Display of the versions of the individual software components.

- Select the *Additional settings* menu.
- Select *Software version* and press *OK* to open the relevant menu.



Software for individual units is displayed. XXXX denotes the version.

- EB Id: XXXX  
The software version of the control and display elements.
- EGL Id: XXXX  
The software version of the control board.
- EZL Id: XXXX  
The software version of the relay board.
- EFU Id: XXXX  
The software version of the frequency converter.

Alterations and updates to software can only be carried out by an authorized Miele service technician.

⚠ Remove any soiling from the control panel and from the front of the appliance straight away.  
Otherwise the surfaces can become discolored or changed.

⚠ All surfaces are susceptible to scratches.  
Contact with unsuitable detergents can alter or discolor the external surfaces.

### Cleaning the control panel

- Clean the control panel with a clean sponge and a solution of dishwashing liquid and hot water or with a clean damp microfiber cloth. Dry the control panel with a soft cloth afterwards.

⚠ Do not use abrasive detergents!  
These can damage the control panel.

### Cleaning the appliance front

- To clean the stainless steel front, use a damp cloth with a solution of dishwashing liquid and hot water or with a non-abrasive cleaning agent for use on stainless steel.

To help prevent re-soiling (fingerprints, etc.), a suitable stainless steel conditioner can be used after cleaning (e.g., Neoblank, which can be obtained from Miele Service).

⚠ Do not use cleaning agents containing ammonia or thinners!  
These agents can damage the surface material.

⚠ Do not hose down the dishwasher or its direct vicinity to clean it, e.g. with a water hose or high-pressure cleaner.

### Cleaning the wash cabinet

The wash cabinet is largely self-cleaning, provided that the correct amount of detergent is always used.

If, despite this, lime scale or grease deposits accumulate in the cabinet, these can be removed with a proprietary dishwasher cleaner (available from Miele).

## Cleaning and care

### Cleaning the door and the door seal

- Wipe the door seal and the area beneath the door regularly with a damp cloth to remove food deposits.
- Wipe away any spillages of food and beverages from the sides of the dishwasher and from the hinges.
- With freestanding dishwashers that have a base facing, please remove spillages of food and beverages from the channel that runs below the door.

⚠ Be cautious of sharp edges when cleaning.  
Danger of cutting yourself.

These surfaces are outside the wash cabinet and are not accessed by water from the spray arms. If soiling is not removed, mold can develop.

### Cleaning the filters in the wash cabinet

The filter combination in the base of the wash cabinet retains coarse soil from the suds solution, preventing it accessing the circulation system and causing blockages in the spray arms.

⚠ This dishwasher must not be used without all the filters in place!

The filters must be checked regularly and cleaned when necessary.

⚠ Caution!  
Danger of injury on glass splinters.

### Cleaning the coarse filter

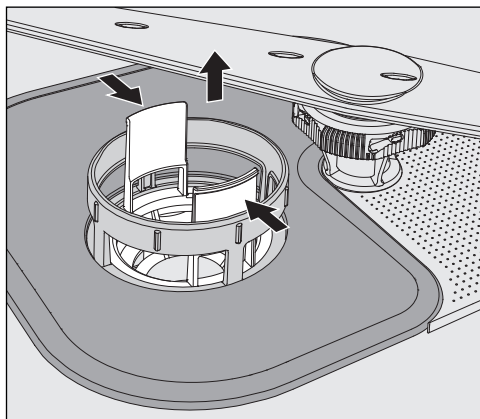

- Press the catches towards each other and remove the coarse filter.
- Rinse the filter thoroughly under running water. If necessary use a soft washing-up brush to remove soiling.
- Replace the filter making sure it engages correctly.

### Cleaning the flat and micro-fine filters

- Remove the coarse filter.

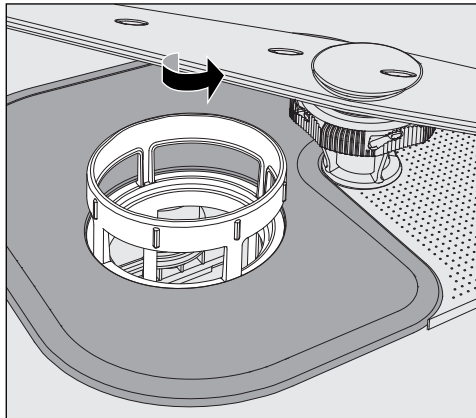

- Grasp the micro-fine filter by the upper rim and turn it in the direction of the arrow to release it. Then lift it out.

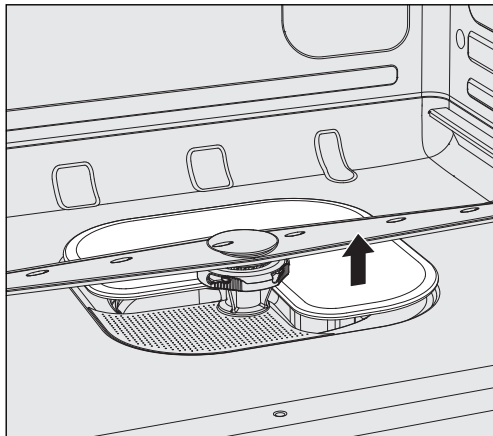

- Remove the flat filter.
- Rinse the filters thoroughly under running water. If necessary use a soft washing-up brush to remove soiling.

Replace the filter combination in the reverse order, turning the micro-fine filter to the left to re-engage it.

The flat filter must lie flat in the bottom of the wash cabinet.

The spray arms will get blocked if the filters are not replaced correctly.

## Cleaning and care

---

### Cleaning the spray arms

This dishwasher has three different spray arms.

Particles of food can get stuck in the spray arm jets and bearings. The spray arms should therefore be inspected and cleaned regularly.

- Turn the dishwasher off.
- Pull the **upper spray arm** downwards to remove it.

The middle and bottom spray arms are secured with a bayonet fitting.

The bayonet fitting on the lower spray arm is colored yellow so that it cannot be mistaken for the fitting on the middle spray arm.

To release the bayonet fitting proceed as follows:

- Using the knurled nut turn the **middle spray arm** to the left as far as it will go and then pull the spray arm downwards to remove it.
- Remove the lower basket.

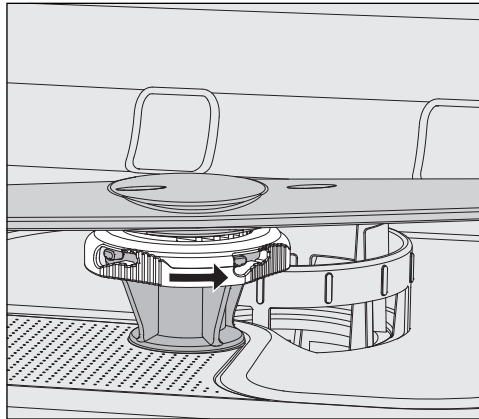

- Using the knurled nut turn the **lower spray arm** to the right as far as it will go and then pull the spray arm upwards to remove it.

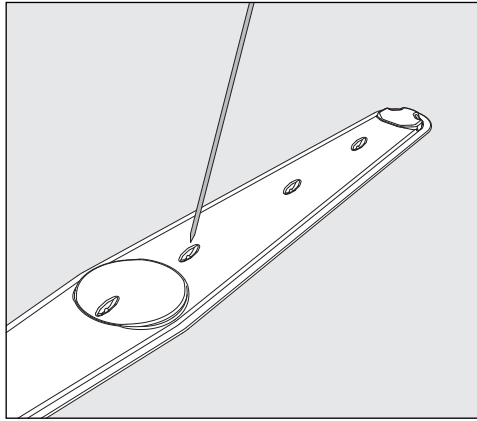

- Use a pointed object to push food particles that are stuck in the spray arm jets into the spray arm.
- Rinse the spray arms thoroughly under running water.

Replace the spray arms and check that they rotate freely.

Make sure that the spray arm with the yellow bayonet fitting is fitted in the bottom of the wash cabinet.



## Frequently asked questions

With the help of the following guide, minor faults in the performance of the appliance, some of which may result from incorrect operation, can be corrected without contacting the Service Department.

Please note that a call-out fee will be applied to unnecessary service visits where the problem could have been rectified as described in these operating instructions.

⚠ Repair work to electrical appliances must only be carried out by a suitably qualified person in strict accordance with current local and national safety regulations. Repairs and other work by unqualified persons could be dangerous. The manufacturer cannot be held liable for unauthorized work.

### Technical problems

Problem	Possible cause and solution
<b>When the dishwasher is turned on with the  button, the display stays dark and the Start/Stop indicator does not flash.</b>	The dishwasher is not plugged in. ■ Insert the plug.
	The circuit breaker has tripped. ■ Reset the circuit breaker (minimum fuse rating - see data plate).
<b>The dishwasher stops during a program.</b>	The circuit breaker has tripped. ■ Reset the circuit breaker (see data plate for the correct fuse rating). ■ If the circuit breaker trips again, contact Miele Customer Service.
<b>One of the following fault messages is displayed:</b>	Before fixing the fault: ■ Turn the dishwasher off with the  button.
Check water intake	There is a problem with the water intake. ■ Open the faucet all the way. ■ Clean the filter in the water inlet (see "Cleaning and care").
Fault 403-405	If Check water intake appears in the display, the control unit is checking the water intake approx. every 30 seconds. If, after three attempts, water is not getting into the dishwasher, one of these numbers will appear in the display and the program will be cancelled. ■ Open the faucet all the way. ■ Turn the dishwasher back on. ■ Select the desired program. ■ Press the <i>Start/Stop</i> button.





## Frequently asked questions

Problem	Possible cause and solution
Fault 406-408	<p>Water inlet fault. One of these numbers will appear in the display if the flow pressure is too low and the program will be cancelled.</p> <ul style="list-style-type: none"> <li>■ The flow pressure at the water intake point is too low (see "Technical data"). Contact Miele Service for advice.</li> </ul>
Fault 412-414	<p>Water inlet fault. One of these numbers will appear in the display if the flow pressure is too high and the program will be cancelled.</p> <ul style="list-style-type: none"> <li>■ The flow pressure at the water intake point is too high (see "Technical data"). Contact Miele Service for advice.</li> </ul>
Check drainage	<p>The water outlet is restricted. There might be water in the wash cabinet.</p> <ul style="list-style-type: none"> <li>■ Clean the filter combination (see "Cleaning and care").</li> <li>■ Clean the drain pump (see "Frequently asked questions").</li> <li>■ Clean the non-return valve (see "Frequently asked questions").</li> <li>■ Remove any kink or loop in the drain hose.</li> </ul>
Fault 433	<p>The door was obstructed when closing and cannot be drawn into the final closed position.</p> <ul style="list-style-type: none"> <li>■ Remove the obstruction from the vicinity of the door.</li> </ul>
Fault XXX <b>(XXX stands for a number)</b>	<p>There may be a technical fault. After a 10 seconds:</p> <ul style="list-style-type: none"> <li>■ Turn the dishwasher back on.</li> <li>■ Select the desired program.</li> <li>■ Press the <i>Start/Stop</i> button.</li> </ul> <p>If the error message is displayed again, there is a technical fault.</p> <ul style="list-style-type: none"> <li>■ Contact Miele Service.</li> </ul>
	<p>The waterproof system has reacted.</p> <ul style="list-style-type: none"> <li>■ Close the faucet.</li> <li>■ Contact Miele Service.</li> </ul>

## Frequently asked questions

### Unusual behavior of the dishwasher

Problem	Possible cause and solution
<b>The dishwasher fails to react when buttons are pressed. The display and indicator lights remain dark.</b>	The dishwasher has turned itself off after the set "switch off after" duration to save energy. <ul style="list-style-type: none"> <li>■ Press the  button to turn the dishwasher back on.</li> </ul>
<b>The following fault message is appears in the display:</b> Salt container lid not closed correctly	The salt reservoir cover is not properly closed. <ul style="list-style-type: none"> <li>■ Close the salt reservoir cover.</li> </ul>
<b>The dispenser cover cannot be closed.</b>	Detergent residue is blocking the latch. <ul style="list-style-type: none"> <li>■ Remove the detergent residue.</li> </ul>
<b>The inside of the door and/or the interior walls are wet after a program has finished.</b>	This is not a fault. It is caused by the drying system. The moisture will dissipate after a short while.
<b>Water remains in the wash cabinet at the end of the program.</b>	Before fixing the fault: <ul style="list-style-type: none"> <li>■ Turn the dishwasher off with the  button.</li> </ul>
	The filter combination in the wash cabinet is clogged. <ul style="list-style-type: none"> <li>■ Clean the filter combination (see "Cleaning and care").</li> </ul>
	The drain pump or non-return valve is blocked. <ul style="list-style-type: none"> <li>■ Clean the drain pump or the non-return valve (see "Frequently asked questions").</li> </ul>
	The drain hose kinked. <ul style="list-style-type: none"> <li>■ Remove the kink.</li> </ul>
	The on-site drain siphon is blocked. <ul style="list-style-type: none"> <li>■ Check and clean the drain siphon.</li> </ul>

### Noises

Problem	Possible cause and solution
<b>There is a knocking noise in the wash cabinet.</b>	<p>A spray arm is hitting the dishware.</p> <ul style="list-style-type: none"> <li>■ Interrupt the program, and rearrange the items which are obstructing the spray arm.</li> </ul>
<b>There is a rattling noise in the wash cabinet.</b>	<p>Dishware is moving around in the wash cabinet.</p> <ul style="list-style-type: none"> <li>■ Interrupt the program and rearrange loose pieces.</li> </ul>
	<p>A foreign object (e.g. a cherry pit) has become lodged in the drain pump.</p> <ul style="list-style-type: none"> <li>■ Remove the foreign object from the drain pump (see "Cleaning the drain pump and non-return valve").</li> </ul>
<b>There is a knocking noise from the water pipe</b>	<p>This may be caused by the installation or the diameter of the water pipe.</p> <p>This has no effect on the functioning of the dishwasher.</p> <ul style="list-style-type: none"> <li>■ If in doubt, contact a plumber.</li> </ul>

## Frequently asked questions

### Poor cleaning results

Problem	Possible cause and solution
<b>The dishes are not clean.</b>	The dishes were not loaded correctly. ■ Please observe the instructions in "Loading the dishwasher."
	The program was not suitable for the requirements. ■ Select a more suitable program (see "Program guide").
	Not enough detergent was dispensed. ■ Use more detergent, or change the brand you are using.
	Items are blocking the path of the spray arms. ■ Rearrange the items so that the spray arms can rotate freely.
	The filter combination in the base of the wash cabinet is not clean or is not correctly fitted. This may cause the spray arm jets to get blocked. ■ Clean and/or fit the filter combination correctly. ■ Clean the spray arm jets, if necessary (see "Cleaning and care").
	The non-return valve is open and blocked. Dirty water has flowed back into the wash cabinet. ■ Clean the drain pump and the non-return valve (see "Frequently asked questions").
	If necessary alter the temperature and / or the holding time for the program being used. ■ Change the relevant parameters for the program (see "Additional settings, Additional functions").
<b>Smearing appears on glassware and cutlery. There is a bluish sheen on the surface of glassware; film can be wiped off.</b>	The rinse aid dosage is set too high. ■ Reduce the dosage (see "Additional settings, Additional functions, Dispensing systems").
<b>Dishware is not dry or cutlery and glasses are spotty.</b>	The rinse aid dosage is set too low or the rinse aid reservoir is empty. ■ Replenish the rinse aid, increase the dosage or change the brand of rinse aid used (see "Adding rinse aid").

## Frequently asked questions

Problem	Possible cause and solution
<b>White residue is visible on cookware and cutlery, clouding occurs on glassware; film can be wiped off.</b>	The rinse aid dosage is too low. <ul style="list-style-type: none"> <li>■ Increase the dosage (see "Additional settings, Additional functions, Dispensing systems").</li> </ul>
	The salt reservoir is empty. <ul style="list-style-type: none"> <li>■ Fill the salt reservoir (see "Filling the salt reservoir").</li> </ul>
	The water softener is programmed to too low for the water hardness level. <ul style="list-style-type: none"> <li>■ Program the water softener to the correct value (see "Additional settings, Water hardness").</li> </ul>
<b>Glasses have a brownish-blue discoloration; the deposit cannot be wiped off.</b>	Detergent deposits. <ul style="list-style-type: none"> <li>■ Switch to another detergent right away.</li> </ul>
<b>Glasses are dull and discolored; the deposit cannot be wiped off.</b>	The glassware is not dishwasher-proof. The surfaces are affected. In the future make sure you purchase dishwasher-proof glassware.
<b>Tea or lipstick stains have not been completely removed.</b>	The wash temperature of the selected program was too low. <ul style="list-style-type: none"> <li>■ Select a program with a higher wash temperature.</li> </ul>
	The bleaching effect of the detergent is too low. <ul style="list-style-type: none"> <li>■ Switch to another detergent.</li> </ul>
<b>Plastic parts are discolored.</b>	Natural dyes e.g. from carrots, tomatoes or ketchup may be the cause. The amount of detergent used or its bleaching effect was not sufficient to deal with natural dyes. <ul style="list-style-type: none"> <li>■ Use more detergent (see "Operation, Adding detergent").</li> </ul> Discolored plastic items will not regain their original color.
<b>There are rust stains on the cutlery.</b>	The "Cold" program was not run after dishwasher salt was added. Traces of salt have gotten into the wash cycle. <ul style="list-style-type: none"> <li>■ Always run the "Cold" program without a load after refilling salt.</li> </ul>
	The affected items are not corrosion resistant. Purchase cutlery which is dishwasher-proof.

## Frequently asked questions

---

### Cleaning the filters in the water inlet

Filters are incorporated into the water inlet connection on the hose to protect the water inlet valve. If these filters get dirty they must be cleaned as otherwise too little water will flow into the wash cabinet.

**⚠** The plastic housing on the water inlet valve contains an electrical component. It must not be dipped in water.

#### To clean the filter

- Disconnect the dishwasher from the water supply and the electrical supply (turn the dishwasher off, unplug it or disconnect or disable the fuse).
- Close the faucet.
- Unscrew the water inlet valve.

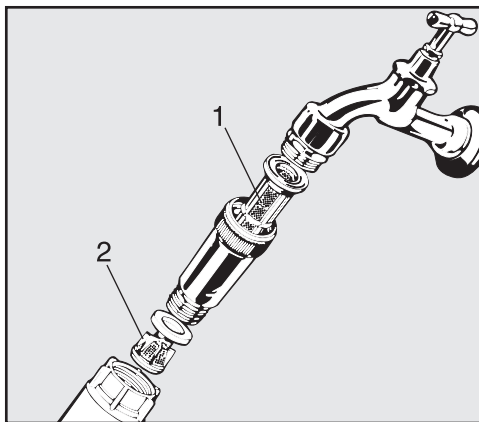

- Carefully pull out the large surface area filter 1.
- Take the seal ring out of the screw connection.
- Withdraw fine filter 2 using pointed pliers.
- Clean the filters or replace them with new ones if necessary.
- Replace the filters and seals, making sure they are sitting correctly.
- Reconnect the hose to the water faucet, making sure the thread goes on straight and not cross-threaded.
- Turn on the water faucet gradually to test for leaks.  
If there is a leak, the inlet hose might not be secured properly, or it may have been screwed on at an angle. Unscrew and reconnect the water inlet hose correctly before tightening it.

### Cleaning the drain pump and non-return valve

If water has not pumped out at the end of a program, there may be a foreign object in the drain pump or blocking the non-return valve. These are easy to remove.

- Disconnect the dishwasher from the water supply and the electrical supply (turn the dishwasher off, unplug it or disconnect or disable the fuse).
- Take the filter combination out of the wash cabinet (see "Cleaning and care").

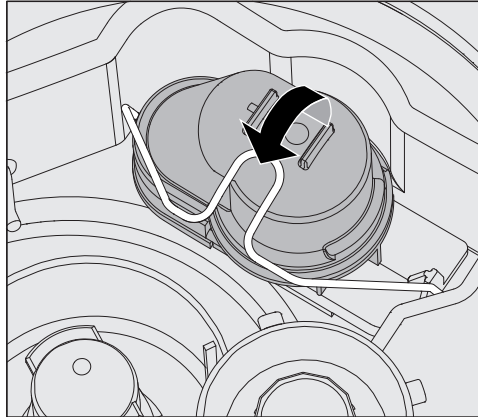

- Lift the locking clamp.
- Lift out the non-return valve and rinse well under running water.
- Make sure that the vent on the external part of the non-return valve is not blocked. (This vent is only visible when the non-return valve has been taken out of the dishwasher). If it is blocked, use a pointed object to release the blockage.

## Frequently asked questions

---

The drain pump is situated under the non-return valve (see arrow).

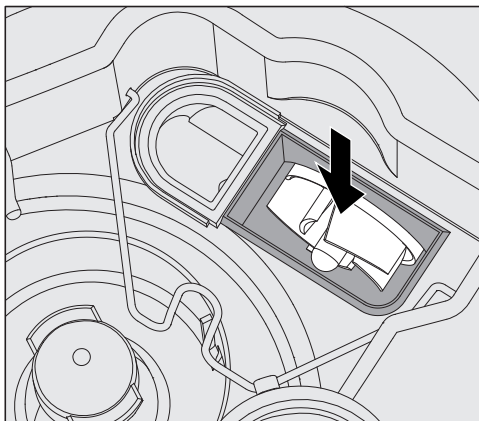

- Check the area around the drain pump for foreign objects (watch out for glass splinters which could cause injury) and remove them before replacing the non-return valve.
- Carefully replace the non-return valve and secure it with the clamp.



### After sales service

If, despite following the instructions in this manual, you are unable to rectify a problem please contact one of the following, quoting the fault code shown in the display:

- your Miele dealer or
- the Miele Technical Service Department.

Contact details for the Miele Technical Service Department can be found at the back of this manual.

- When contacting Miele, please quote the model number of your dishwasher together with the 8 digit machine number.

The model number and the machine number are both shown on the data plate, located at the top of the door.

## Installation

⚠ In order to reduce the risk of damage from condensation, the furniture in the area around the commercial dishwasher should be designed for commercial use.

The dishwasher must be installed in a secure and level position. Any unevenness in the floor level and height of the appliance must be compensated for by adjusting the four feet.

If the dishwasher is to be installed next to other appliances or furniture or in a niche, make sure the space provided is at least 23 5/8" (60 cm) wide and 23 5/8" (60 cm) deep.

## Building under

⚠ To ensure the stability of undercounter commercial dishwashers, they must only be installed beneath a continuous countertop that is bolted to the adjacent cabinetry.

When installed under a continuous counter, please ensure that the space provided is at least 23 5/8" (60 cm) wide, 23 5/8" (60 cm) deep and 32" 5/16" (82 cm) high.

The dishwasher feet must not be unscrewed by more than 2 3/8" (6 cm).

If the dishwasher is fitted with a lid, it can be removed as follows:

- Remove both securing screws on the back of the dishwasher with a screwdriver.
- Open the door.

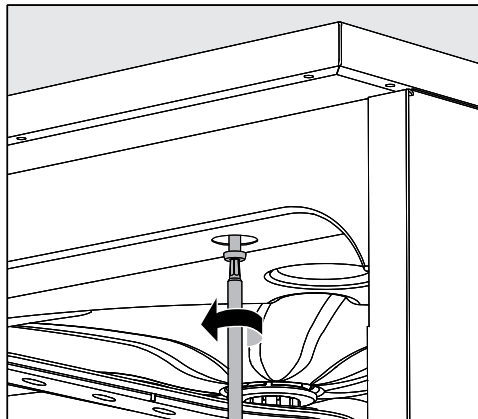

- Unscrew the left and right fixing screws with a screwdriver.
- Lift the appliance lid upwards to remove.

## Levelling and securing the dishwasher

To guarantee stability; the dishwasher must be secured to the counter after levelling.

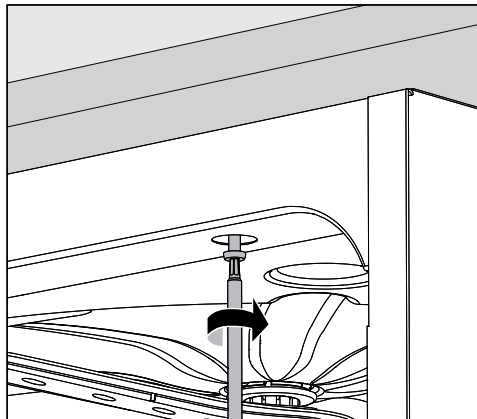

- After levelling, secure the dishwasher to the continuous counter. With the door open, screw into the counter through the holes in the front trim on the left and right hand sides of the dishwasher.

With stainless steel or stone counters; the dishwasher must be secured at the sides to the left and right adjacent cupboards with two screws on each side.

Special screws are supplied in the accessory pack.

Drill holes located in the side wall in front of the door seal must be used for this.

The gaps between built-under appliances and adjacent cabinetry must not be filled with silicone sealant as this could compromise the ventilation of the circulation pump.

Depending on the building-under situation, the stainless steel cover plate supplied can be used to protect the lower edge of the counter against steam damage.

## Installation

---

### Floor anchors for free-standing units

During conversion to a free-standing unit, both rear appliance feet of the dishwasher must be secured against tipping using the floor anchors.

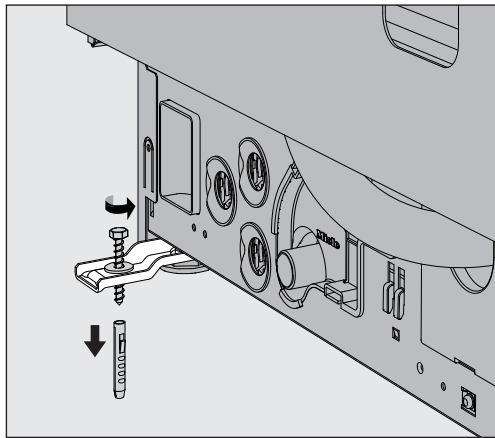

- Attach the floor anchors to the floor using the included fastening materials at the distance of both rear appliance feet.
- The fastening screws can be used in both wood floors and, with the help of dowels, concrete floors.
- Push the dishwasher into the provided floor anchor seats.

### Moving the dishwasher

Before moving the dishwasher, screw in the adjusting feet fully so that they do not get damaged.

⚠ Do not lift the dishwasher by any protruding components, e.g. the control panel.  
They could break off.

⚠ Only transport the dishwasher on a trolley in its original packaging. For subsequent moves, the dishwasher must be placed on a continuous base to avoid damage.

### Electrical connection

 All electrical work must be carried out by a suitably qualified electrician in accordance with local and national safety regulations.

- The plug connection must comply with national regulations. (The electrical outlet must be accessible after the appliance has been installed.)
- If the appliance is hard wired, a multiple-pole circuit breaker must be used. The circuit breaker must have a contact opening width of at least 3 mm and be lockable in open position.
- To increase safety, it is recommended that the machine be connected to a ground fault circuit breaker with a trip current of 30 mA.
- If necessary, equipotential bonding must be carried out.
- The power cord may only be replaced by an original Miele part.
- For technical data, see the data plate or the attached wiring diagram!

The appliance must only be operated with the voltage, frequency, and fuse rating shown on the **data plate**.

This appliance **can be converted to a different type of power supply** in accordance with the conversion diagram and wiring diagram supplied.

The **conversion diagram** and the **data plate** are supplied with the appliance.

### Grounding connection

The ground lead must be connected to the screw connection point (marked with the ground symbol ) at the back of the machine.

**WARNING**  
**THIS APPLIANCE MUST BE GROUNDED**

## Connecting the water supply

⚠ The water in the dishwasher is NOT safe to drink!

Do not re-use removable hose attachments. Use the hose supplied with this dishwasher.

- The dishwasher must be connected to the water supply in accordance with local regulations.
- The water used must at least comply with regulations for drinking water quality. If the water supply has a high iron content, there is a danger of corrosion occurring on items being cleaned in the dishwasher, as well as the appliance itself. If the chloride content of the water exceeds 100 mg/l the risk of corrosion to items being cleaned in the dishwasher will be further increased.
- In certain regions (e.g. mountainous regions), the water composition may cause precipitates to form, requiring the use of softened water for the dishwasher.
- A backflow preventer is not required; the dishwasher corresponds with the valid standards for the protection of drinking water.
- The water pressure (flow pressure) must amount to at least 200 kPa overpressure (200 kPa = 29 psi). At a water pressure (flow pressure) below 200 kPa, the water intake time extends automatically. The maximum permissible static pressure amounts to 1000 kPa (overpressure) (1000 kPa = 145.04 psi). If the water pressure does not lie in the 200-1000 kPa range (29 - 145.04 psi), ask Miele Service how to proceed.
- The dishwasher is supplied as standard for connection to cold water (blue-coded hose) **and** hot water up to 150°F / 65°C (red-coded hose). Connect the inlet hoses to the water faucet valves for cold and hot water.
- If there is no hot water supply, the intake hose with the **red** marking must also be connected to the cold water supply.
- Connect the intake hose for the steam condenser (without water protection device) to a cold water faucet.
- A water faucet valve with a 3/4" male thread must be provided on site. It should be easily accessible so that the water supply can be turned off when the appliance is not in use.
- The intake hose is an approx. 5' 7" (1.7 m) long pressure hose DN 10 with a 3/4 inch screw connection. For the extension, a 5' 7" (1.7 m) long, flexible metal hose (test pressure 140 bar) is available. The dirt filter in the screw connection may not be removed.
- Install the coarse filter (supplied in accessory pack) between the water faucet valve and the inlet hose (see Cleaning and care, Water inlet").

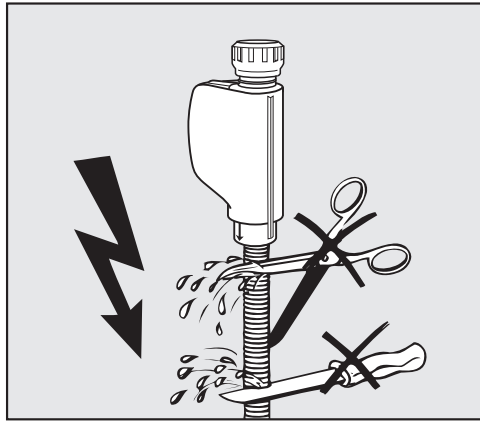

⚠ Do **NOT** shorten or otherwise damage the inlet hoses (see diagram).

Also refer to the supplied installation diagram!

### Connecting the water drain

- The drain is equipped with a non-return valve which prevents waste water from flowing back into the dishwasher through the drain hose.
- The dishwasher should preferably be connected to a **separate** on-site drainage system. If no separate connection is available, we recommend connection to a double chamber siphon. The on-site connection must be between 1 ft (0.3 m) and 3' 3" (1 m) height, measured from the lower edge of the appliance. If the connection is lower than 1 ft. (0.3 m) the drain hose must be placed in an arc at least 1 ft (0.3 m) high.
- The dishwasher is equipped with a 4' 11" (1.5 m) flexible drain hose with an internal diameter of 7/8" (22 mm). Hose clips are supplied with the dishwasher.
- The drain hose may not be shortened. An additional hose and adapter can be used to extend the drain hose. The drain hose length must not exceed 13' 1 1/2" (4 m).
- The drainage system must be able to accommodate a minimum drainage flow of 42 gpm (16 l/min).

⚠ Make sure that there are no kinks in the hose, and that it is not squashed or stretched.

Also refer to the supplied installation diagram!



## Technical details

Height without lid	2' 8 5/16" (82 cm) adjustable + 2 3/8" (6 cm)
Height of free-standing model	2' 8 7/8" (83.5 cm) adjustable + 2 3/8" (6 cm)
Width	1' 11 9/16" (59.8 cm)
Depth with door open	1' 11 5/8" (60 cm) 3' 11 1/4" (120 cm)
Weight (net)	154 lbs (70 kg)
Voltage, rated load, fuse	See data plate
Power cord	Approx. 5' 7" (1.7 m)
Water temperature: Cold water connection Hot water connection	Max. 68°F (20°C) Max. 149°F (65°C)
Static water pressure	Max. 1000 kPa (145 psi) overpressure
Recommended flow pressure: Cold and hot water connection Water connection for steam condenser	200 kPa (29 psi) overpressure 100 kPa (14.5 psi) overpressure
Minimum flow pressure: Cold water connection Hot water connection	100 kPa (14.5 psi) overpressure 40 kPa (5.8 psi) overpressure
Drain pump height	Min. 1' (0.3 m), max. 3' 3 3/8" (1 m)
Drain hose length	Max. 13' 1 1/2" (4 m)
Ambient temperature	41°F to 104°F (5°C to 40°C)
Relative humidity maximum linear decreasing to	80% for temperatures up to 88°F (31°C) 50% for temperatures up to 104°F (40°C)
Altitude above sea level	Up to 6561 ft (2000 m) *
Inlet hoses	Approx. 5' 7" (1.7 m)
Drain hose	Approx. 4' 11" (1.5 m)
Safety class	IP21
Noise emission values  Sound power in LwA Sound pressure in LpA	Built-under appliance with wooden beam in front of plinth in Short program 57 dB(A) 45 dB(A)
Certification marks	CSA approval, NSF
Manufacturer's address	Miele & Cie. KG, Carl-Miele-Straße 29, 33332 Gütersloh, Germany

\* At altitudes above 6561 ft. (2000 m) the boiling point of water is reduced. Dishwashers installed above this altitude must be modified by the Miele Service Department.





Please have the model and serial number  
of your appliance available before  
contacting Technical Service.

---

**Miele**  
**PROFESSIONAL**

## **U.S.A.**

**Miele, Inc.**

### **National Headquarters**

9 Independence Way  
Princeton, NJ 08540  
Phone: 800-991-9380  
609-419-9898  
Fax: 609-419-4241  
[www.mieleusa.com](http://www.mieleusa.com)

### **Technical Service & Support**

#### **Nationwide**

Phone: 800-991-9380  
Fax: 800-220-1348  
[proservice@mieleusa.com](mailto:proservice@mieleusa.com)

## **Germany**

### **Manufacturer**

Miele & Cie. KG  
Carl-Miele-Straße 29  
33332 Gütersloh

## **Canada**

**Importer**

**Miele Limited**

### **Professional Division**

161 Four Valley Drive  
Vaughan, ON L4K 4V8  
Phone: 1-888-325-3957  
Fax: 1-800-803-3366  
[www.mieleprofessional.ca](http://www.mieleprofessional.ca)  
[professional@miele.ca](mailto:professional@miele.ca)

### **Miele Professional**

#### **Technical Service**

Phone: 1-888-325-3957  
Fax: 1-800-803-3366  
[serviceprofessional@miele.ca](mailto:serviceprofessional@miele.ca)