

NZ24T4360RK

SAMSUNG

24" Radiant Electric Cooktop



Signature Features

Flexible Cooktop

- Whether you're boiling water, melting chocolate or simmering sauce, there's an element for your needs.

Digital Touch Controls

- Digital touch controls accurately control your heating and provide an easy-to-clean surface.

Indicator Light

- Hot Surface Indicator light lets you know the surface is hot.

Available Color



Black



Digital Touch Controls



Dual Element

Features

- 4 Elements Flexible Cooktop
- One Dual Element
 - Left Front: 5/8", 2.0 kW
- Three Single Elements:
 - Right Front: 6", 1.2 kW
 - Right Rear: 6", 1.2 kW
 - Left Rear: 7", 1.5 kW
- Digital Touch Controls
- 3.5 kW Total Power

Convenience

- Hot Surface Indicator Light
- Easy-To-Clean Glass, Ceramic Cooktop
- Kitchen Timer
- Child Safety Lock

NZ24T4360RK

SAMSUNG

24" Radiant Electric Cooktop

Installation Requirements

Countertop cut-out and minimum clearance dimensions:

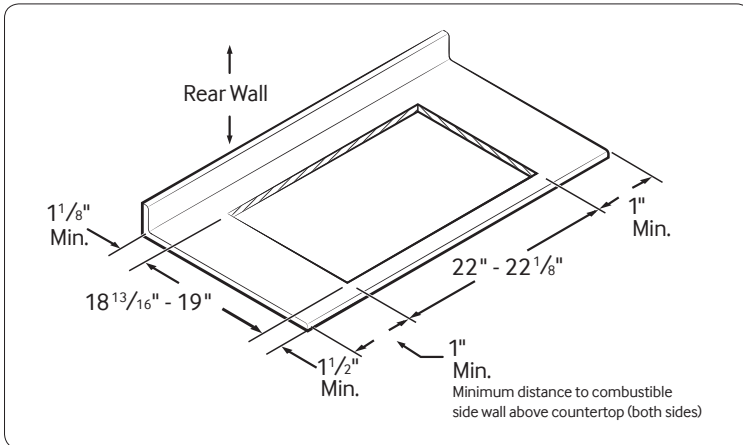

Total Power

3.5 kW

Power Source

240V / 60 Hz / 14.5A

Radiant Cooktop

- Right Front: 1.2 kW
- Left Front: 2.0 kW (Dual Ring)
- Right Rear: 1.2 kW
- Left Rear: 1.5 kW

Warranty

One (1) Year Parts and Labor
Five (5) Years Glass Cooktop Part and Radiant Heater Part (Parts Only)

Product Dimensions & Weight (WxHxD)

Outside (Max) Cooktop Dimensions: 23 5/8" x 3 3/8" x 20 7/16"

Cooktop Cut-Out Dimensions: 22 1/8" x 3 3/8" x 19"

Weight: 24.3 lbs

Shipping Dimensions & Weight (WxHxD)

Dimensions: 25 11/16" x 6 1/8" x 22 5/8"

Weight: 29.3 lbs

Color

Black

Model #

NZ24T4360RK

UPC Code

887276430522

Installing Over a Single Oven

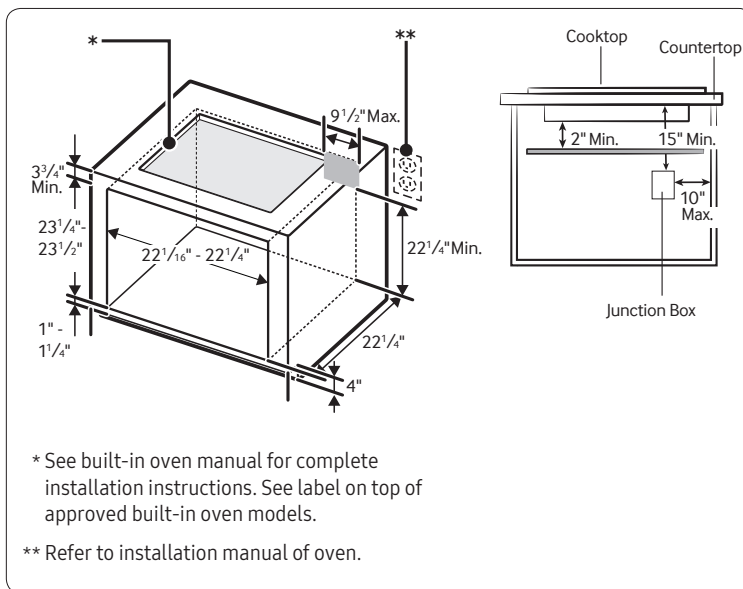

Cooktop Dimensions

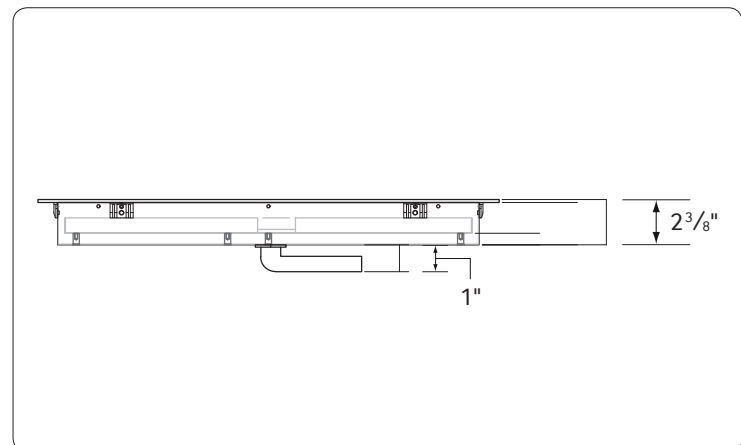
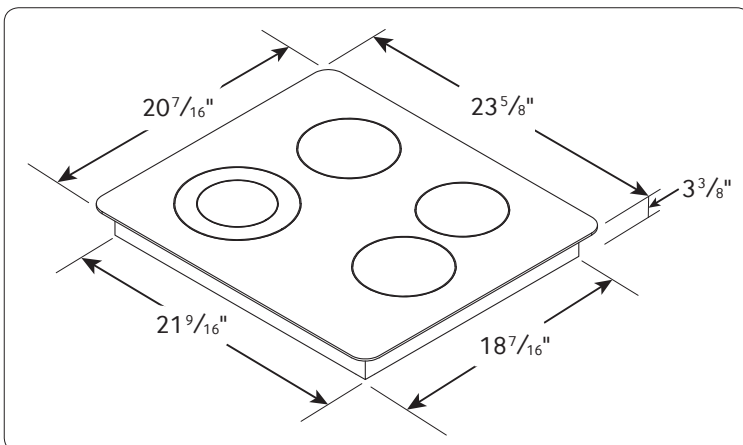

Actual color may vary. Design, specifications, and color availability are subject to change without notice. Non-metric weights and measurements are approximate.

©2020 Samsung Electronics America, Inc. 85 Challenger Road, Ridgefield Park, NJ 07660. Tel: 800-SAMSUNG. samsung.com. Samsung is a registered trademark of Samsung Electronics Co. Ltd.