

Oven, 24", 11 Function

Series 9 | contemporary

Black Glass with Stainless Steel



With generous capacity and beautiful contemporary styling, this built-in oven will complement your kitchen design perfectly.

- Three cubic feet total capacity with eleven oven functions including Aero™ Pastry, Roast and Rapid Proof
- Moisture control and even heat distribution thanks to ActiveVent™ and AeroTech technology
- Optional non-tip, full-extension sliding shelves for safe removal of hot dishes

DIMENSIONS

Height	23 ⁹ / ₁₆ "
Width	23 ¹ / ₂ "
Depth	22 ¹ / ₄ "

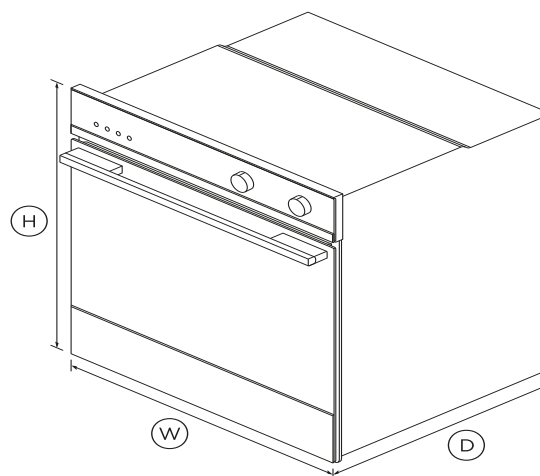

FEATURES & BENEFITS

Generous capacity

With a generous sized internal cavity, you can create several dishes at once using multiple shelves.

Perfect Results

Our built-in ovens feature ActiveVent technology for optimized moisture levels, and AeroTech™ for even heat distribution. Get perfect results even when you're using multiple shelves.

Multi-function flexibility

11 functions with pre-set temperatures including Aero™ Pastry, Roast and Rapid Proof mean no matter what you're cooking, you've got the right heat to match.

Seamless fit

Designed to fit seamlessly in your kitchen, this built-in oven fits flush with cabinetry to minimize gaps and add to a cohesive aesthetic.

Cleaning is simple

Cleaning this built-in oven is quick and easy thanks to the catalytic liners which absorb oil and fat splashes during cooking.

Refined styling

With sophisticated handle styling and stainless steel finish, our built-in ovens are designed to match the rest of Fisher & Paykel's kitchen appliance family.

Safe and sound

The CoolTouch door features triple glazing and a cooling system that ensures it's safe to touch from the outside - protecting both your hands and the surrounding cabinetry.

SPECIFICATIONS

Accessories

Chromed shelf runners	•
Flat wire shelf	•
Food probe	•
Full Extension Telescopic	Optional (part 565048)
Meat probe	•
Optional Accessory round	Part 81671
Optional round handle	Part 81645
Pyrolytic proof shelf runners	•
Step down wire shelf	•

Capacity

Shelf positions	6
Total	3 cu ft
Usable capacity	2.5 cu ft

Cleaning

Acid resistant graphite enamel	•
Pyrolytic proof shelf runners	•
Removable oven door	•
Removable oven door inner	•
Removable shelf runners	•
Self-clean	•

Controls

Audio feedback	•
Automatic cooking/minute	•
Automatic pre-set	•
Automatic rapid pre-heat	•
Behind glass capacitive touch	•
Celsius/Fahrenheit	•
Electronic capacitive touch	•
Electronic clock	•
Electronic oven control	•
Interior light	2 x 25W (halogen)
Precise electronic temperature	•
Sabbath mode	•
Turned stainless dials with	•

Functions

Aero Broil	•
AeroTech™ technology	•

Aero™ Bake	•
Bake	•
Broil	•
Classic bake	•
Maxi Broil	•
Number of functions	11
Rapid proof	•
Roast	•
Self-clean function	•
Vent bake	•
Warm	•

Performance

ActiveVent™ system	•
AeroTech™ technology	•
Automatic rapid pre-heat	•
Broil power	3000W
CoolTouch door	Triple glazed
Whisper quiet cooking	•

Power requirements

Amperage	19A
Supply frequency	60Hz
Supply voltage	208 - 240V

Product dimensions

Depth	22 1/4 "
Height	23 9/16 "
Width	23 1/2 "

Safety

Advanced cooling system	•
Balanced oven door	•
Catalytic venting system	•
Control panel key lock	•
Full extension telescopic	•
Non-tip shelves	•

Warranty

Parts and labor	2 years
-----------------	----------------

SKU	81206
-----	-------

The product dimensions and specifications in this page apply to the specific product and model. Under our policy of continuous improvement, these dimensions and specifications may change at any time. You should therefore check with Fisher & Paykel's Customer Care Centre to ensure this page correctly describes the model currently available. Â© Fisher & Paykel Appliances Ltd 2019.

Other product downloads available at fisherpaykel.com



User Guide



Service & Warranty Booklet



Installation Guide



Resources (zip)



A PEACE OF MIND SALE

24 Hours 7 Days a Week Customer Support

T 1300 650 590 **W** www.fisherpaykel.com