

# SP18FC

## 15" Marine Crescent Ice Maker • Marine Series

### FEATURES & BENEFITS



STAINLESS  
SOLID



BLACK  
SOLID



WHITE  
SOLID

#### PERFORMANCE

- Uses less than 3 gallons of water to produce up to 23 lbs of ice per day
- Up to 12 lbs in ice storage capacity
- Crescent ice cube dimensions: 1/2" W x 3/4" H x 1/2" L
- On/Off switch is conveniently located on the grille
- Available in 115 or 220 - 240 volts

#### INTERIOR/EXTERIOR

- No drain required
- Zero clearance door swing is field reversible
- Standard travel package includes door latch and ice flap, ensuring safe-at-sea storage
- Corrosion and UV resistant components provide product longevity in harsh environments

#### INTEGRATION

- Unit is designed to be built-in or can be freestanding
- Accepts a 1/4" custom panel
- 1/2" flange mounts flush to cabinet

### MODEL DETAILS

Model	Voltage	Door Swing	Finish	Shipping Weight
ULN-SP18FCS-03A	115	Field Reversible	Stainless Solid	65 lbs
ULN-SP18FCS-20A	220 - 240	Field Reversible	Stainless Solid	65 lbs
ULN-SP18FCB-03A	115	Field Reversible	Black Solid	68 lbs
ULN-SP18FCB-20A	220 - 240	Field Reversible	Black Solid	68 lbs
ULN-SP18FCW-03A	115	Field Reversible	White Solid	68 lbs
ULN-SP18FCW-20A	220 - 240	Field Reversible	White Solid	68 lbs

### ACCESSORIES

Model	Description	Finish	Shipping Weight
WATERHOOKUP	Braided water supply line kit	na	2 lbs

### DIMENSIONS

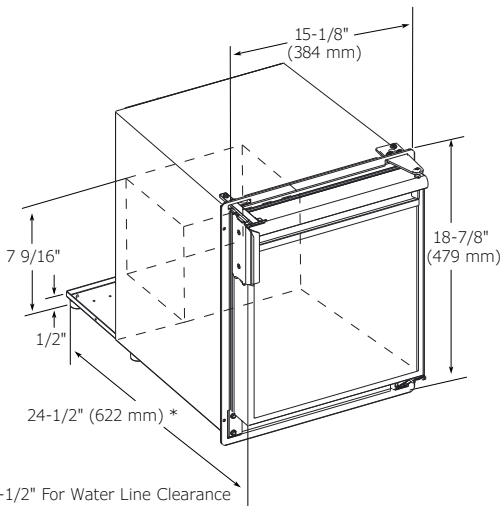

### CABINET CUT-OUT

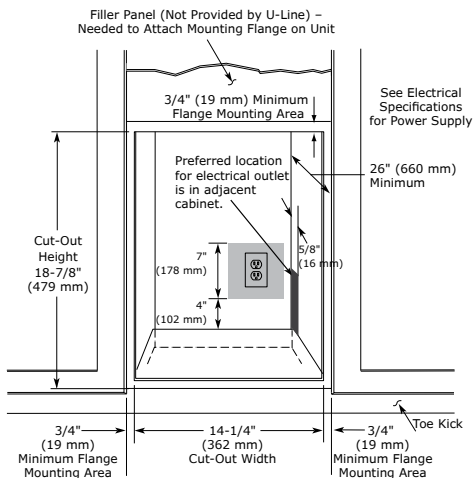

### INSTALLATION NOTES

No additional clearance around sides, top or rear of unit is needed for ventilation.

Do not obstruct front grille air flow.

### SPECIFICATIONS

Model	SP18FC
Amps: Running (115 v)	2.5
Amps: Running (220 - 240 v)	1.2
Amps: Max Start Up (115 v)	18
Amps: Max Start Up (220 - 240 v)	6
Control Type	Mechanical Dial
Defrost Type	Manual
Dimensions: Product Depth	24 1/2" / 622 mm
Dimensions: Product Height	18 7/8" / 479 mm
Dimensions: Product Width	15 1/8" / 384 mm
ENERGY STAR	na
Ice Production Per Day	23 lbs
Ice Storage	12 lbs
Product Weight: Max	59 lbs
Refrigerant Type	R134A
Sabbath (Star K Certified)	No

UL listing only applies to 115 v models.

Please visit [u-line.com](http://u-line.com) to view this model's User Guide. All specifications are subject to change without notice.



### ELECTRICAL REQUIREMENTS

This unit requires a grounded a polarized 115 VAC, 60 Hz, 15 A power supply (normal household current).