

Miele

T1 Ventless Heat Pump Dryer

TWI180 WP, TWF160 WP



T1 Ventless Heat Pump Dryer

SPECIFICATIONS	
Unit Width	23 ¹ / ₂ " (596 mm)
Unit Height	33 ¹ / ₂ " - 34 ³ / ₄ " (850 - 882 mm)
Unit Depth- Excluding Door Dimension	23 ⁵ / ₈ " (600 mm)
Unit Depth- Including Door Dimension	25 ⁵ / ₁₆ " (643 mm)
Door Clearance	18 ¹ / ₄ " (463 mm)
Built-In	
Minimum Cabinet Opening Width	23 ¹ / ₂ " (596 mm)
Minimum Cabinet Opening Height	33 ¹ / ₂ " (850 mm)
Interior Volume	
Drum Volume	4.1 (116 L)
Rated Load Capacity	17.6 lbs (8 kg)
Plumbing	
Drain Hose	5' 3" (1.6 m) flexible drain hose is supplied. May be extended up to 13' (4 m) Delivery head must not exceed 5' (1.5 m)
Electrical	
Electrical Requirements	120V, 60Hz, 15A 220V, 30A, 60Hz (Used with NEMA Adapter)
Power Cord	NEMA 5-15 plug, 6'7" ft (2 m)
Shipping	
Shipping Weight	145 lbs (66 kg)
Shipping Dimensions	26" W x 37" H x 27 ³ / ₁₆ " D
Support	
Call Miele	(800) 999-1360
Miele Website	www.mieleusa.com
20/20 Link	2020technologies.com



TWI 180 WP
Item# 12WI1802USA



TWF 160 WP
Item# 12WF1602USA

Installation Accessories:



WTV 502
Stacking kit

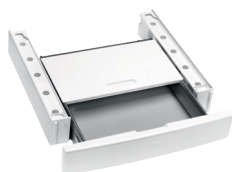

WTV 512
Stacking kit with drawer



WTS 510
Stacking kit with drawer



NEMA Adapter
NEMA 14-30/2x5-15 Adapter

T1 Ventless Heat Pump Dryer

PRODUCT VIEWS

Isometric View

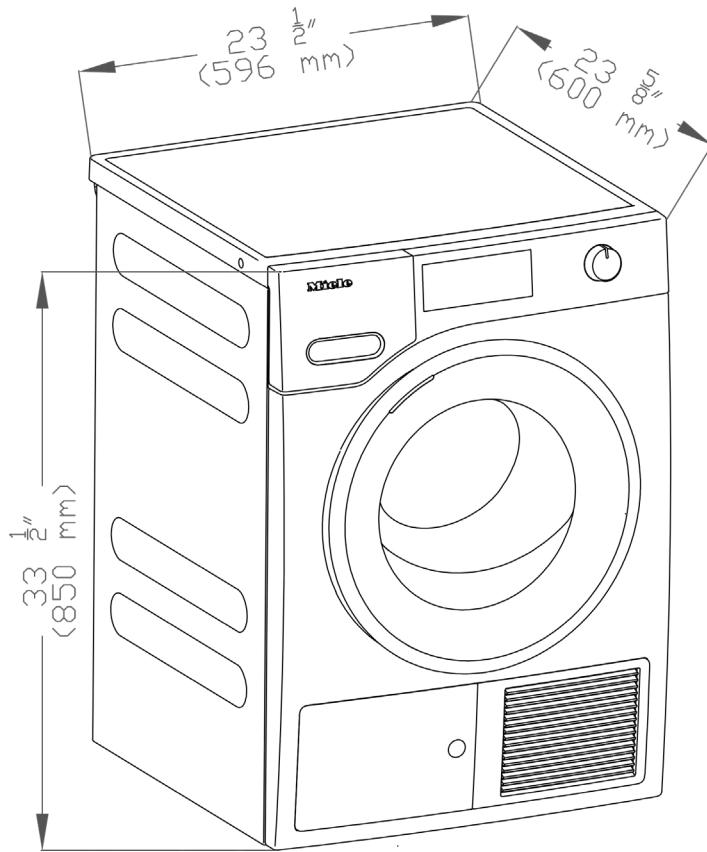

Front View

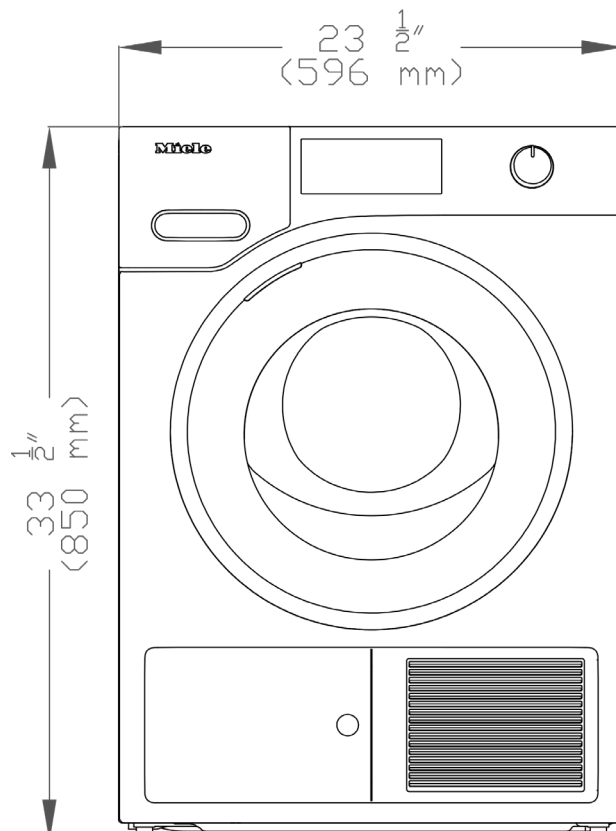

T1 Ventless Heat Pump Dryer

PRODUCT VIEWS

Side View

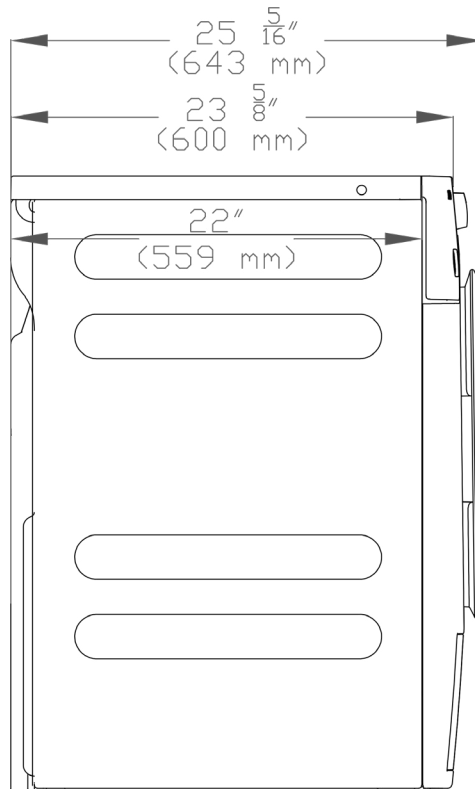

Side View With Door Open

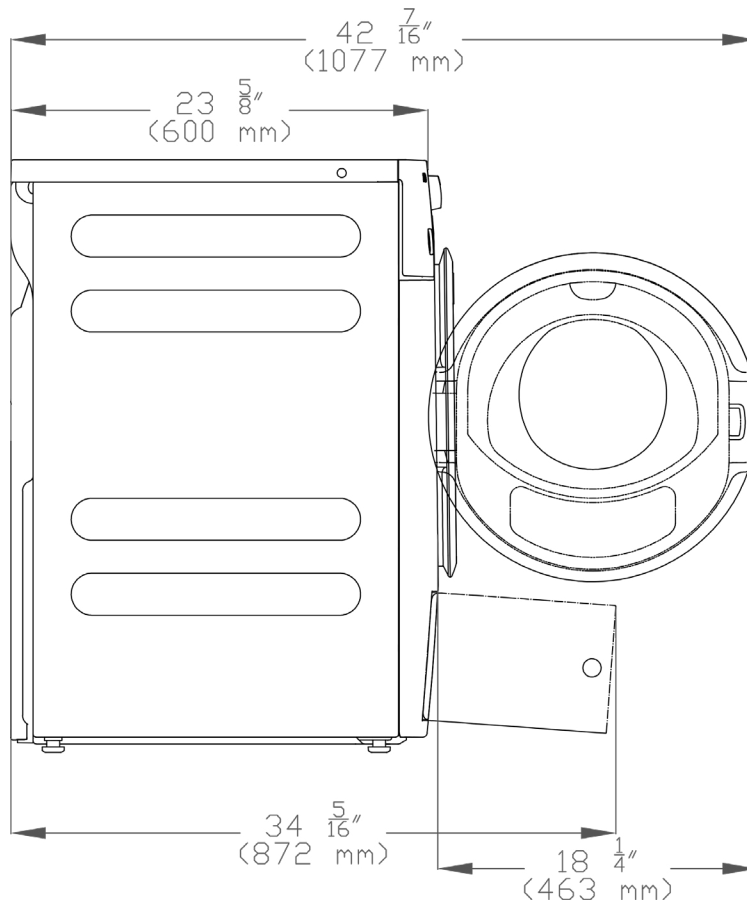

T1 Ventless Heat Pump Dryer

PRODUCT VIEWS

Door Swing

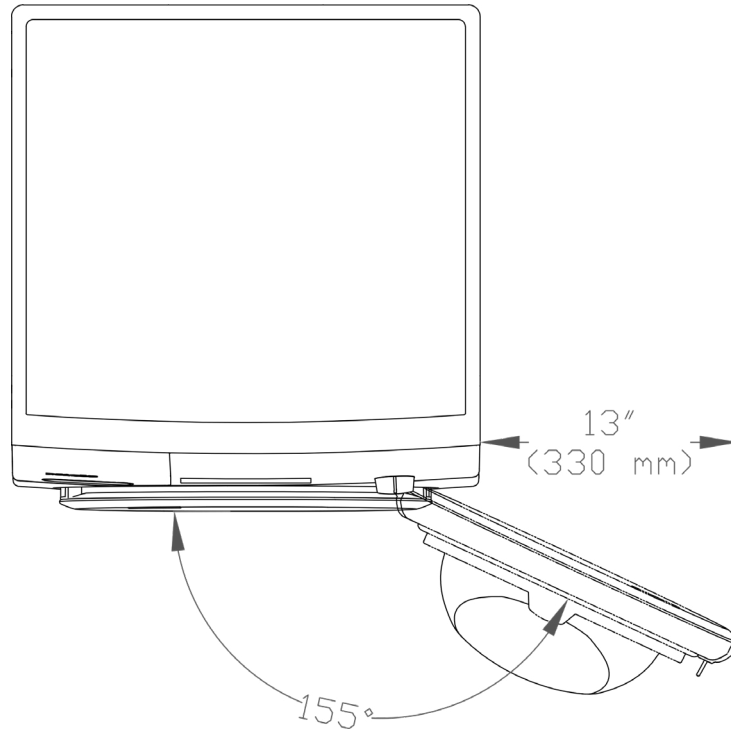

Rear View

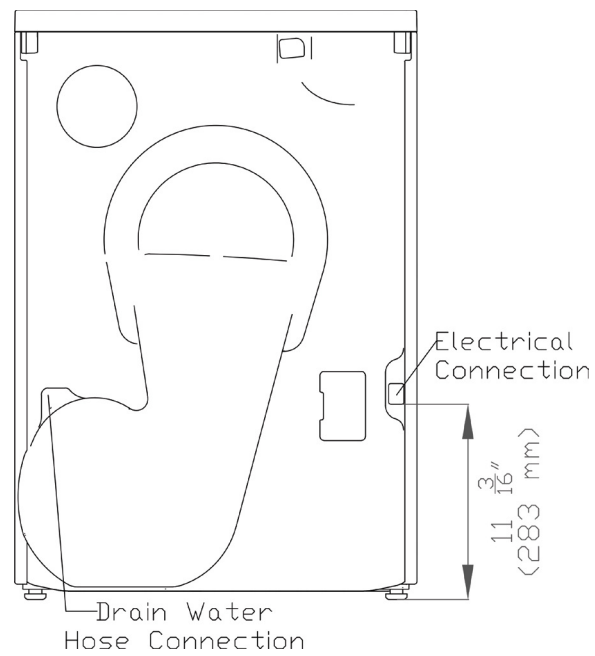

T1 Ventless Heat Pump Dryer

Built-in Niche

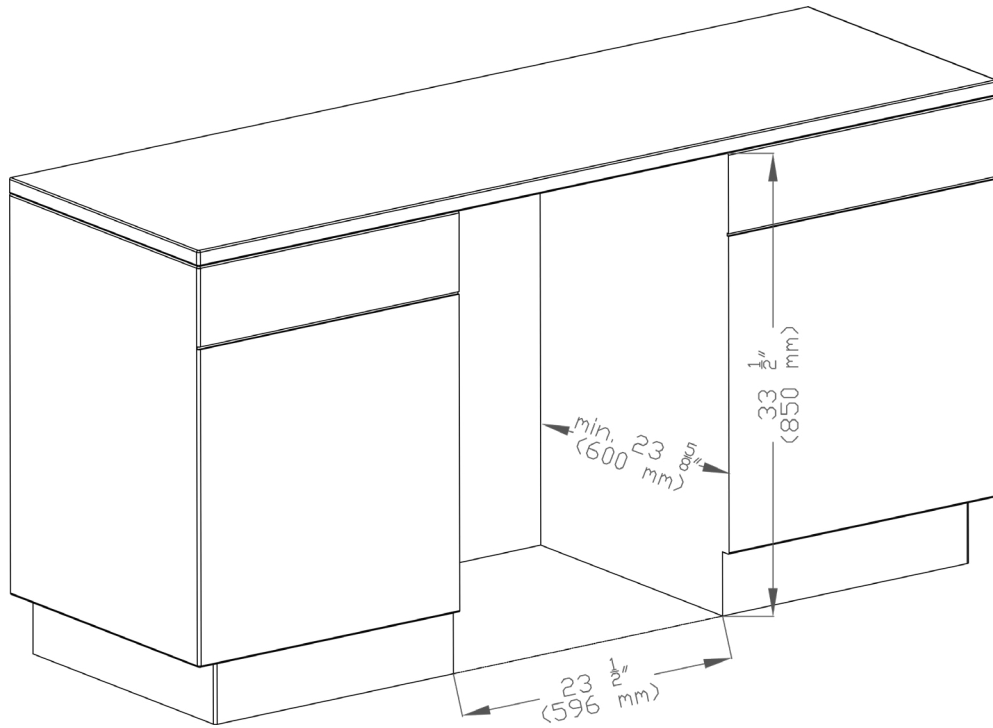

T1 Ventless Heat Pump Dryer

Stacked in Closet

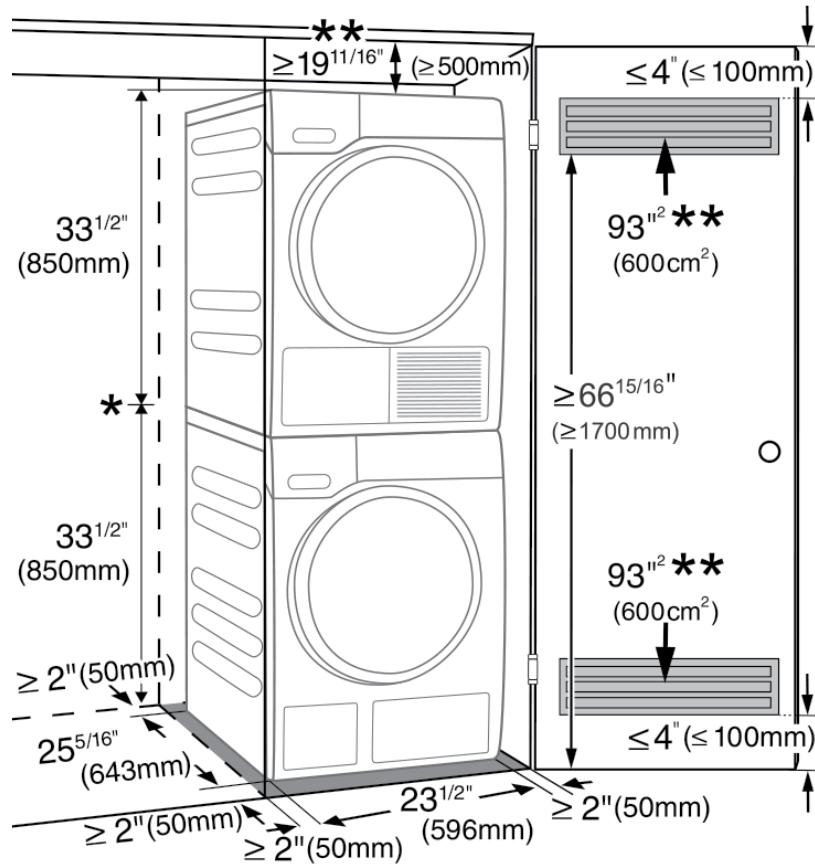

- * Height with Stacking Kit
 WTV502 = 67^{3/8}" (1711 mm)
 WTV512 = 71^{1/8}" (1806 mm)

** If it is not possible to fulfill the dimension specification you may have longer drying and process time.

T1 Ventless Heat Pump Dryer

Stacking Kit WTV 502 (Optional Accessory)

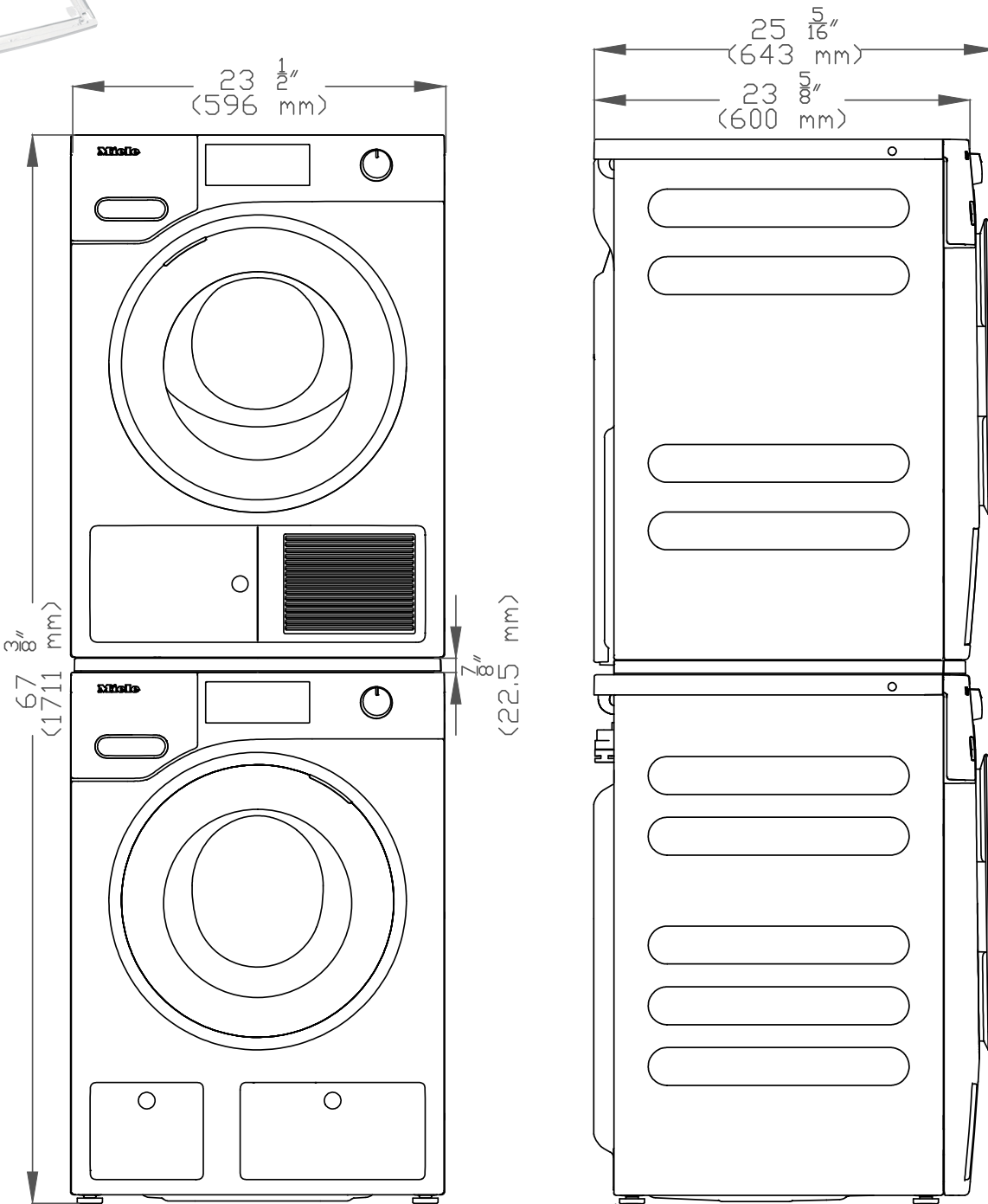

T1 Ventless Heat Pump Dryer

Stacking Kit With Drawer WTV 512 (Optional Accessory)

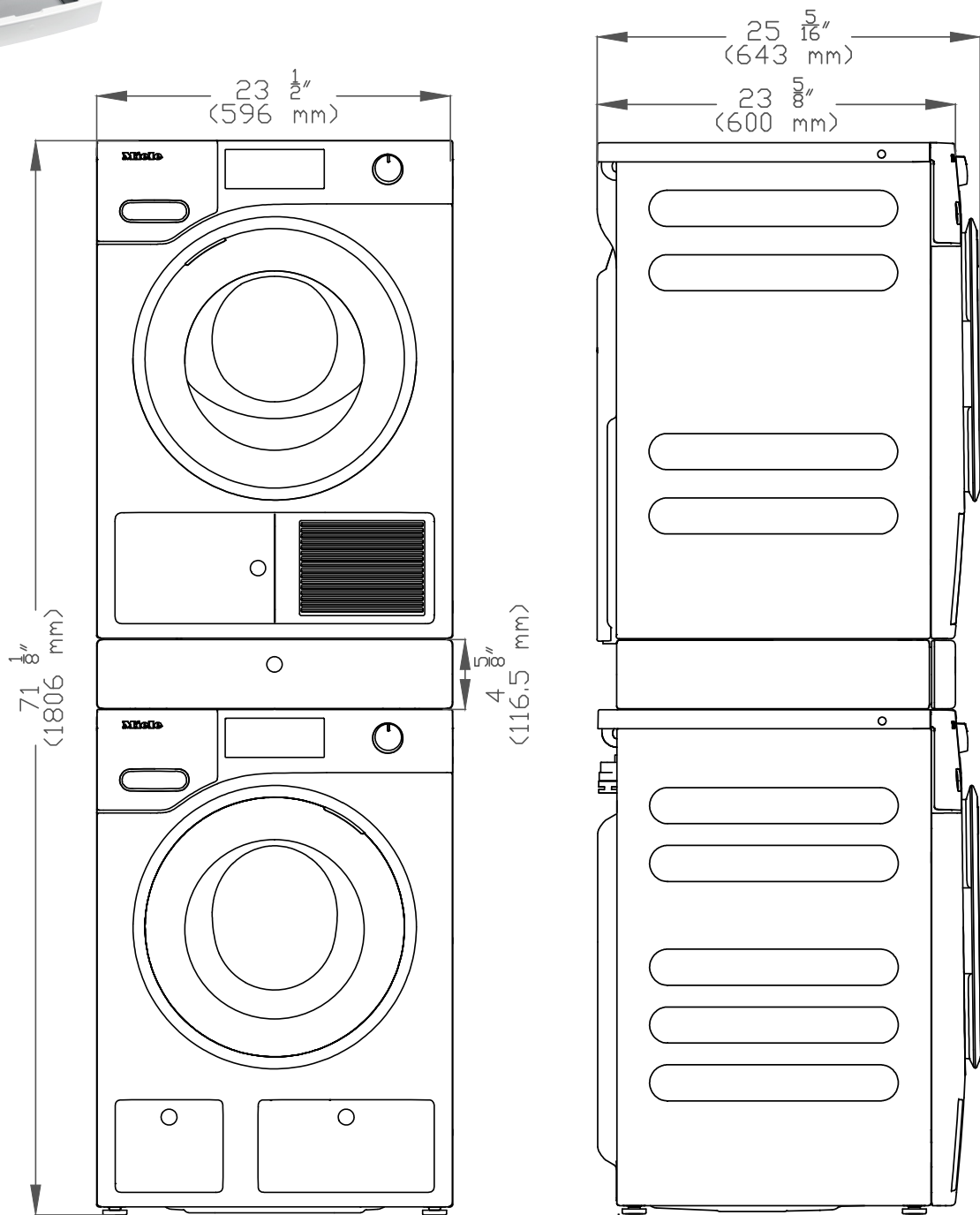

T1 Ventless Heat Pump Dryer

Plith WTS 510 (Optional Accessory)

