

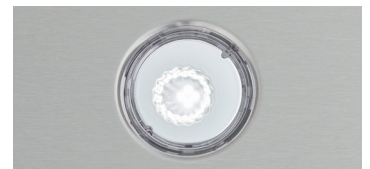

## UCB3 Series

Characterized by its sleek profile, this under-cabinet range hood models will add a subtle hint of joy to contemporary and modern decors.

- Powered by internal blower system with 550 MAX blower CFM. Ultra quiet 0.9 sonas at normal setting.
- 4-speed soft-touch controls with blue or white backlighting and 5 minute delay-off feature keeps hood running after cooking to ensure smoke & odors have cleared the environment.
- Three-level Integrated LED modules provide even lighting over the cooktop.
- Hybrid aluminum mesh & stainless steel low profile baffle filters effectively capture grease and are dishwasher-safe making it easier to have a cleaner, odor-free kitchen.
- Code Ready™ Technology (CRT) provides ability to reduce airflow to 300 CFM to address local codes or make-up air requirements.
- Modern design with choice of standard white, grey and black glass colors or interchangeable optional color panels to help personalize your kitchen decor.

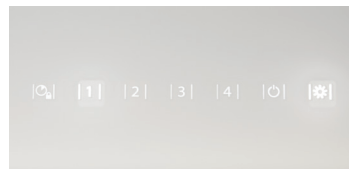

# best®

PERFORMANCE THAT INSPIRES

At **BEST**, we make high performance range hoods that perform beautifully. Astonishingly quiet. Impressively effective. Remarkably efficient. And perfectly suited for the most distinguished kitchens.

Whether it's the centerpiece of the room or letting its surroundings shine, **BEST** is where high-end performance inspires.

Installation height above the cooking surface: 24"-30"

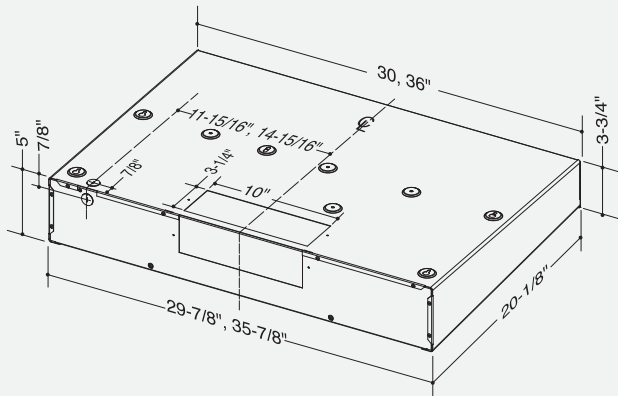

If needed, ask a recommended installer to limit discharge to 300 CFM.

## HOOD SIZES\*

Internal Blower - Depth: 20-1/8"

Black glass:	30"	UCB3I30SBB	36"	UCB3I36SBB
White glass:	30"	UCB3I30SBW	36"	UCB3I36SBW
Grey glass:	30"	UCB3I30SBS	36"	UCB3I36SBS
Require a glass panel (sold separately)	30"	UCB3I30SBN	36"	UCB3I36SBN

\* For exact dimensions, please refer to the technical drawing of each model.

## FEATURES

Finish	Brushed Stainless Steel (Grade 430)
Lighting Type	PURLED™, 5.5W each, 1100 Lumens, 3000K
Number of Lamps	2
Lighting Levels	3
Lighting Lamps Included	Yes
Control Type	4-speed Soft Touch
Control Features	Heat Sentry™, Delay-off
Remote Control	Not Available
Filter Type	Hybrid Baffle
Non-ducted Capability	No

## HOOD BLOWER INCLUDED UCB3

Internal	
Max Blower CFM*	550

## ACCESSORIES

Glass Panels	White, Grey, Black, Emerald, Lime, Orange, Purple, Red
--------------	--

## INSTALLATION REQUIREMENTS

Amps @ 120V	1.8
Electrical Connection	Plug In
Duct Size: Internal Blower	3-1/4" x 10"
Duct Direction	Vertical/Horizontal
Backdraft Damper	Included

\*MAX Blower CFM indicates the performance of the hood blower in open air.

## HVI PERFORMANCE

### SONES

	Low Speed	High Speed
Horizontal	1.0	9.5
Vertical	0.9	9.5

### CFM

	Low Speed	High Speed
Horizontal	160	500
Vertical	160	440

## AIRFLOW PERFORMANCE

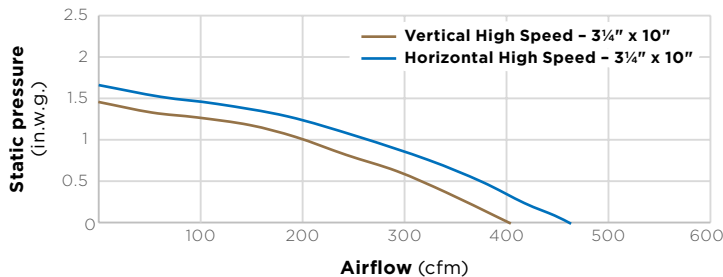

HVI-2100 CERTIFIED RATINGS comply with new testing technologies and procedures prescribed by the Home Ventilating Institute, for off-the-shelf products, as they are available to consumers. Product performance is rated at .01 in. static pressure, based on tests conducted in AMCA's state-of-the-art test laboratory. Sones are a measure of humanly-perceived loudness, based on laboratory measurements.



BESTRANGEHOODS.COM  
USA 800-558-1711

BESTRANGEHOODS.CA  
CANADA 800-567-3855

