

# Oven, 24", 16 Function, Self-cleaning

Series 9 | Contemporary

Stainless Steel



A highlight of the Fisher & Paykel collection, this Series 9 oven with touchscreen guided cooking helps to ensure every dish is cooked to perfection.

- Touchscreen guided cooking capability offers helpful tips for different food types as well as full recipes
- 3 cu ft total capacity, with 16 oven functions including Pastry Bake, Roast, Air Fry and Dehydrate
- Moisture level control with ActiveVent technology
- Pyrolytic self-cleaning function breaks down food residue for an easy clean

## DIMENSIONS

Height	23 9/16"
Width	23 7/16"
Depth	22 1/4"

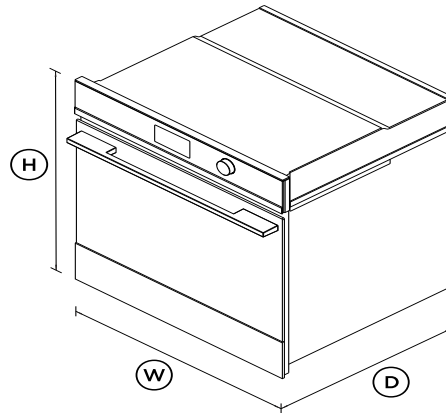

## FEATURES & BENEFITS

### COOK WITH CONFIDENCE

Using the large 5" touchscreen interface, you can cook with a favourite method, a hero ingredient, or a go-to cooking function or recipe. Your oven will guide you through the steps, or change the temperature and heat type automatically, depending on your selection.

### GENEROUS CAPACITY

With an exceptional 3 cu ft total capacity, you can create several

perfectly cooked dishes at once using multiple shelves. Non-tip, full-extension shelves help to ensure safe removal of hot dishes.

### EXCEPTIONAL PERFORMANCE

Our unique cooking technologies were developed to deliver perfect results. ActiveVent ensures optimized moisture levels, while AeroTech™ circulates heat evenly for a consistent temperature.

### SAFE AND SOUND

The CoolTouch door of this built-in oven is safe to touch from the outside. Sturdy, fully extendable shelves slide all the way out, reducing the need for you to reach inside.

### SELF-CLEANING

Pyrolytic self-clean breaks down food residue at a very high temperature, leaving a light ash that's easily removed with a damp cloth. The enamel coated side racks don't need to be removed when using this function.

### DESIGN FREEDOM

Designed to fit seamlessly into your kitchen, this built-in oven features premium materials and detailing to support a cohesive, considered kitchen design.

### MULTI-FUNCTION FLEXIBILITY

Each function has been tailored, tested and perfected to ensure that no matter what you're cooking, you've got the right heat to match. A Wired Temperature Sensor precisely monitors cooking in real time, giving you complete control.

## SPECIFICATIONS

### Accessories

Broil rack	1
Full extension telescopic	1 set
Pyrolytic proof shelf runners	1 set
Roasting pan	1
Smokeless broil tray	1

Step down wire shelf	1
Wired food probe	1

**Capacity**

Shelf positions	6
Total capacity	3cu ft
Usable capacity	2.5cu ft

**Cleaning**

Acid resistant graphite enamel	•
Pyrolytic self-clean	•
Removable oven door	•
Removable oven door inner	•
Removable shelf runners	•

**Controls**

Automatic pre-set	•
Celsius/Fahrenheit	•
Guided cooking by food type	•
Halogen lights	•
Precise electronic temperature	•
Sabbath mode	•
Soft close doors	•
Wi-Fi connectivity	•

**Functions**

Aero Bake	•
Aero Broil	•
Air fry	•
Bake	•

Broil	•
Classic bake	•
Dehydrate	•
Number of functions	16
Pastry Bake	•
Pizza bake	•
Rapid proof	•
Roast	•
Self-clean	•
Slow cook	•
True Aero	•
Vent bake	•
Warm	•

**Performance**

ActiveVent™ system	•
AeroTech™ technology	•
Automatic rapid pre-heat	•
Fan Element Power	2500W

**Product dimensions**

Depth	22 1/4"
Height	23 9/16"
Width	23 7/16"

SKU	82525
-----	-------

The product dimensions and specifications in this page apply to the specific product and model. Under our policy of continuous improvement, these dimensions and

specifications may change at any time. You should therefore check with Fisher & Paykel's Customer Care Centre to ensure this page correctly describes the model currently available. ? Fisher & Paykel Appliances Ltd 2020

---

Other product downloads available at [fisherpaykel.com](https://fisherpaykel.com)



Service & Warranty



Installation Guide Oven



Datasheet Oven



**A PEACE OF MIND SALE**

24 Hours 7 Days a Week Customer Support

T 1.888.936.7872 **W**[www.fisherpaykel.com](https://www.fisherpaykel.com)