

PTD700LSN

GE Profile™ 30" Smart Built-In Convection Double Wall Oven with Left-Hand Side-Swing Doors

DIMENSIONS AND INSTALLATION INFORMATION (IN INCHES)

NOTE: Wall coverings, countertops and cabinets surrounding the wall oven must be able to withstand a temperature of up to 200°F (94°C).

NOTE: If the cabinet in which the wall oven is installed does not have a solid bottom, two braces or runners must be installed to support the weight of the oven. The runners and braces must support up to 400 lbs (181 kg).

NOTE: Door handle protrudes 3" from door face. Cabinets and drawers on adjacent 45° and 90° walls should be placed to avoid interference with the handle.

ATTENTION INSTALLER: Electric wall ovens are NOT approved for installation with a plug and receptacle. They must be hard wired into an approved junction box.

IMPORTANT: Before installing, consult installation instructions packed with product for current dimensional data.

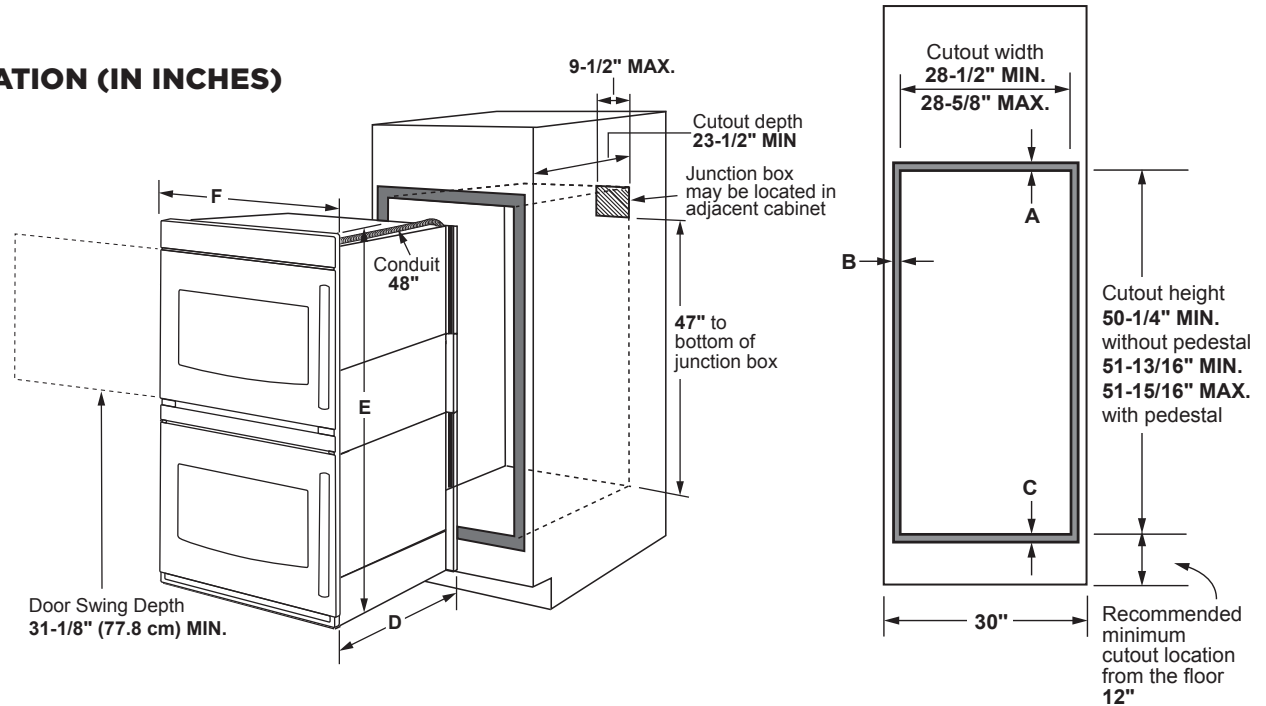

Dimension and installation information are shown in inches.

KW RATING	
240V	9
208V	6.8
BREAKER SIZE	
240V	40 Amps
208V	40 Amps

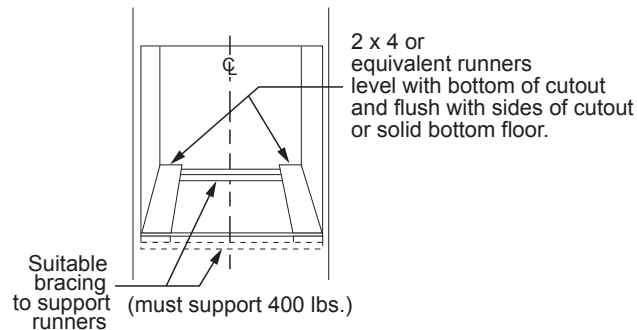

PTD7000

Cabinet	30"
A - Overlap of oven at top of cutout	1"
B - Overlap of oven other side of edge of cutout	11/16"
C - Overlap of oven at bottom of cutout	1-1/4"
Oven	
D - Install depth	23-1/2"
E - Overall height with trim	53"
F - Overall width	29-3/4"



For answers to your GE Profile™ Series or GE Appliances product questions, visit our website at geappliances.com or call GE Answer Center® Service, 800.626.2000.



Listed by Underwriters Laboratories



PTD700LSN

GE Profile™ 30" Smart Built-In Convection Double Wall Oven with Left-Hand Side-Swing Doors

DIMENSIONS AND INSTALLATION INFORMATION (IN INCHES)

NOTE: 30" Double electric wall ovens are approved for installation above 27" and 30" warming drawers.

IMPORTANT: Before installing, consult installation instructions packed with ALL products for current dimensional and combination data.

WHEN TO USE THE PEDESTAL RAILS:

When replacing an older GE Appliances 30" double wall oven with a new GE Appliances model. Cutout Height = 51-13/16" to 51-15/16". This is our traditional cutout height.

WHEN NOT TO USE THE PEDESTAL RAILS:

When replacing a 30" double wall oven from another manufacturer (ie; Whirlpool) with a new GE Appliances model. Cutout height = 50-1/4". You will need to verify that the existing cutout matches the 50-1/4" dimension.

If the new GE Appliances 30" double wall oven is being installed into new construction (ie; not a replacement), then the recommended installation is to use the pedestal rails.

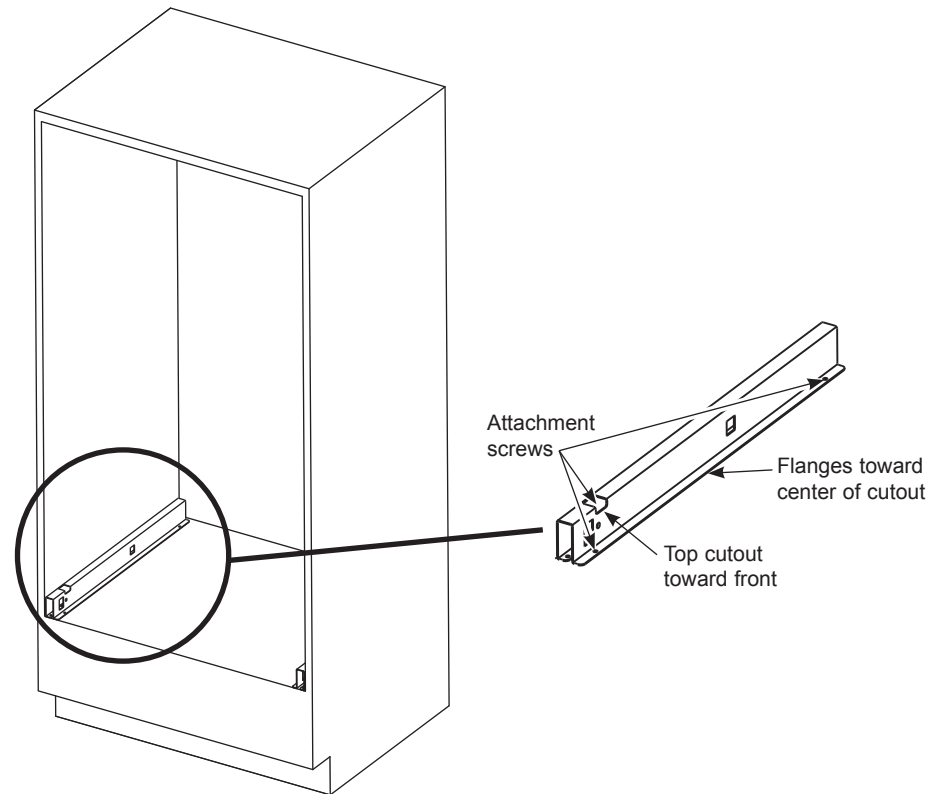

For answers to your GE Profile™ Series or GE Appliances product questions, visit our website at geappliances.com or call GE Answer Center® Service, 800.626.2000.

Specification Revised 7/20

PTD700LSN

GE Profile™ 30" Smart Built-In Convection Double Wall Oven with Left-Hand Side-Swing Doors

FEATURES AND BENEFITS

Swing Door – An innovative door design that opens to the side instead of down, eliminating awkward reaching.

Precision Cooking Modes* – Simplify the cooking process with precision cooking modes that automatically track progress, and make time and temperature adjustments (upper oven).

No Preheat Air Fry – Integrated hot air frying technology gives you crispy results in your oven without using oil (upper oven).

No Preheat – Eliminate the need for preheating and save time with a variety of precision cooking modes.

Built-in WiFi – This smart oven features built-in WiFi so you can control oven functions with the SmartHQ app on your smart device.

Full-Color Display – Easily navigate wall oven settings thanks to a 7" touchscreen display.

True European Convection with Direct Air – This oven features True European Convection, an advanced convection system that uses a third heating element and reversing fan for the highest level of heat and air circulation.

Easy-Glide, Never-Scrub Rack – This smooth-gliding oven rack can be left in the oven during the self-clean cycle so you never have to scrub.

Temperature Probe – A precision temperature probe connects to the oven to ensure your food is properly cooked.

Self-Clean with Steam Clean – This self-cleaning oven uses optional steam cleaning for light soils to clean the oven cavity with less heat and odor.

Fit Guarantee – This oven will fit your existing cut-out, or GE Appliances will help pay for modifications up to \$300.

Model PTD700LSNSS – Stainless Steel

*Available once connected to WiFi.

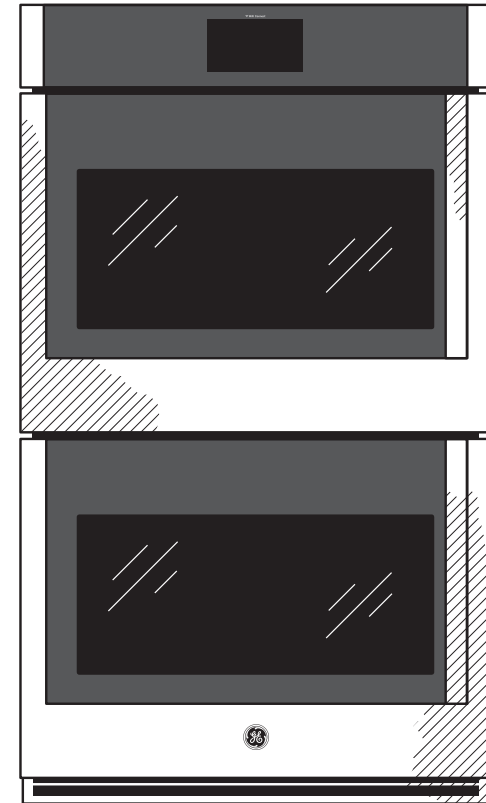

Visit geappliances.com for more info

