



## IPB9 Series

This island hood features a modern chimney design paired with unmatched performance. This hood looks spectacular from any angle and at the same time handles the needs of pro-style cooking.

- Powered by the exclusive iQ Blower System™ 1500 MAX blower CFM with GPS Technology for the quietest, most energy efficient and fastest smoke and odor removal available in a range hood. Ultra-quiet 0.4 sones at normal setting. External blower options also available.
- 4-speed electronic controls with a 10 minute delay-off feature keeps hood running after cooking to ensure smoke and odors have cleared the environment, and the filter clean reminder helps ensure optimal performance.
- Two-level halogen cooktop lighting. (Bulbs included.)
- Distinctive, hybrid aluminum mesh and stainless steel Hi-Flow™ baffle filters effectively capture grease and are dishwasher-safe making it easier to have a cleaner, odor-free kitchen.
- Optional Remote Control allows the busy cook to stay in control from anywhere in the kitchen.



# best®

PERFORMANCE THAT INSPIRES

At **BEST**, we make high performance range hoods that perform beautifully. Astonishingly quiet. Impressively effective. Remarkably efficient. And perfectly suited for the most distinguished kitchens.

Whether it's the centerpiece of the room or letting its surroundings shine, **BEST** is where high-end performance inspires.

Installation height above the cooking surface: 24"-36"

Telescopic flue for 8'-9' ceiling is standard.  
Optional flue extensions for 10'-11' ceiling.

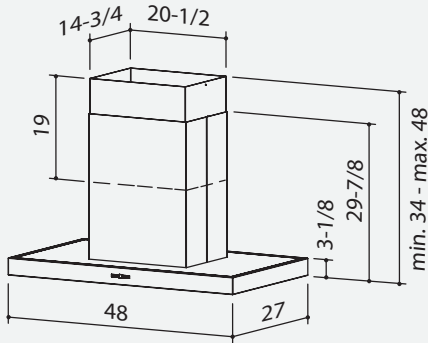

## HVI PERFORMANCE

### INTERNAL BLOWER - IPB9IQ

#### SONES

Normal	Medium*	High*	Boost
0.4	4.0	7.5	11.5

#### CFM

Normal	Medium*	High*	Boost	Boost
295	615	880	0.25 in. w.g. 1020	0.1 in. w.g. 1100

\* Where noted performance rating is not HVI certified but was established in accordance with HVI Standardized test procedure.

## AIRFLOW PERFORMANCE

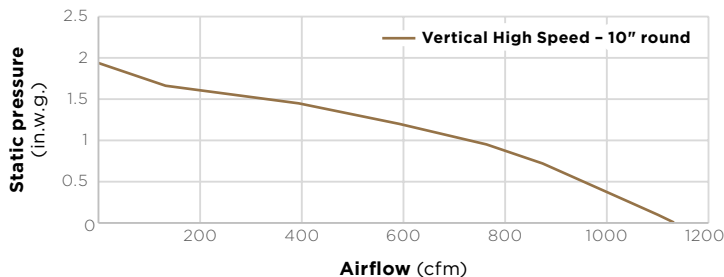

HVI-2100 CERTIFIED RATINGS comply with new testing technologies and procedures prescribed by the Home Ventilating Institute, for off-the-shelf products, as they are available to consumers. Product performance is rated at .01 in. static pressure, based on tests conducted in AMCA's state-of-the-art test laboratory. Sones are a measure of humanly-perceived loudness, based on laboratory measurements.

## HOOD SIZES\*

### Internal Blower, Single - Depth 27"

48" IPB9IQT48SB

### External (blower sold separately) - Depth 27"

48" IPB9E48SB

\* For exact dimensions, please refer to the technical drawing of each model.

## FEATURES

Finish	Brushed Stainless Steel (Grade 430)
Lighting Type	Halogen, T4, G9, 25W
Number of Lamps	4
Lighting Levels	2
Lighting Lamps Included	Yes
Control Type	3-speed Plus Boost Electronic Pushbutton with Display
Control Features	Heat Sentry™, Delay Off, Filter Clean Reminder
Remote Control	Optional ACR3
Filter Type	Hi-Flow Baffle
Non-ducted Capability	No

## HOOD BLOWER INCLUDED IPB9IQ

Internal	iQ12
Max Blower CFM*	1500

## HOOD BLOWER OPTIONS (blowers sold separately)

Refer to external blower's specification sheets for HVI performance (sones and CFM).

External In-line	ILB3	ILB6	ILB9	ILB11
Max Blower CFM*	300	675	900	1500
External Exterior	EB6	EB9	EB12	EB15
Max Blower CFM*	665	890	1300	1650

## ACCESSORIES

10'-11' Flue Extension (ducted)	AEIPB9SB
Universal MUA Damper	MD6TU, MD8TU, MD10TU (Requires Fresh Air Inlet)
Fresh Air Inlet	641FA, 643FA, 610FA

## INSTALLATION REQUIREMENTS

Amps @ 120V: Internal Blower	8.5
Electrical Connection	Direct Wire
Duct Size: Internal Blower	10"
Duct Size: External Blower	10"
Duct Direction	Vertical
Backdraft Damper	Included

\*MAX Blower CFM indicates the performance of the hood blower in open air.



BESTRANGEHOODS.COM  
USA 800-558-1711

BESTRANGEHOODS.CA  
CANADA 800-567-3855

99045187E 10/21

